

CESVA

SC420

**Sound Level Meter
Spectrum Analyser
USER MANUAL**

M_SC420_v0014_20150522_ENG

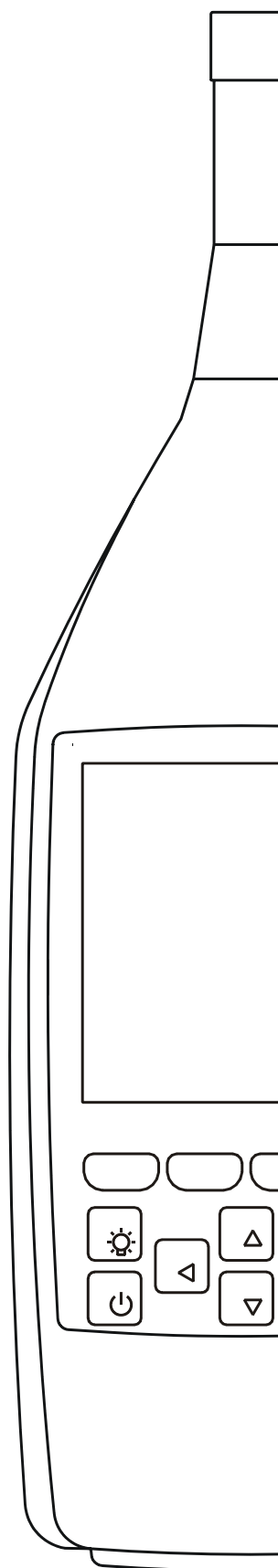

Since its beginnings in Barcelona in 1969, **CESVA** has been devoted to manufacturing sound equipment and instrumentation through research, development and innovation, and by registering its own patents.

We belong to national and international committees for the establishment and revision of standards and regulations.

CESVA has a fast and efficient distribution network in over 40 countries around the world.

We offer our customers an after-sales service to ensure the long life of our instruments. Periodic tests and calibration services are also available.









Our website is the focal point for finding information on our products, requesting no-obligation quotes, downloading software, contacting us and being kept updated about all the training events and exhibitions we are present at on a regular basis.

Taking care of our customers and listening to what they tell us means we are closer to them and are able to offer the measurement solution that fully meets their needs.

The Bluetooth trademark is the property of Bluetooth SIG, Inc.

1. What does this manual cover?	8
2. Equipment and literature	9
3. General device description	10
3.1 SC420 sound level meter spectrum analyser	10
3.2 Main features of the SC420	11
3.3 Device components	14
4. Inputs and outputs	16
4.1 SC420 inputs and outputs	16
4.2 Communications inputs and outputs	17
4.3 AC Output	17
4.4 Digital inputs and outputs	17
5. Keypad	19
6. Screen	21
6.1 Indicator area	21
6.2 Work area	23
6.3 Timing area	23
6.4 Memory area	24
6.5 Contextual area	24
7. Power	25
7.1 Power sources	25
7.1.1 Battery power	25
7.1.2 Power via USB	26
7.1.3 Mains feeder	26
7.2 Energy saving	26
7.3 Power for environmental monitoring	26
8. Assembling and dismantling the device	28
8.1 Windscreen	28
8.2 Extension cable	29
8.2.1 Removing and connecting the preamplifier	29
8.2.2 Connecting the extension cable	30
8.3 Outdoor kit	31

9. Switching the device on and off	32
9.1 Switching the device on	32
9.1.1 Initial SC420 self-check	33
9.2 Turning the device off	34
9.3 Switching the light on and off	34
10. Checking the device	35
10.1 Checking the SC420	35
11. Measuring and recording	37
11.1 Prior steps	37
11.2 Taking a measurement	38
11.3 Making a recording	38
11.4 Overload indicator	39
11.5 Under-range indicator	40
12. Menu	41
12.1 Accessing the menu	41
12.2 Menu areas	42
12.3 Navigating through the menu	42
13. Measurement modes	43
13.1 Selecting the measurement mode	43
13.2 Sound level meter mode	44
13.2.1 Sound level meter mode functions	44
13.2.2 Sound level meter mode prior adjustments	45
13.2.3 Sound level meter mode screens	45
13.3 1/1 spectrum analyser mode (OPTIONAL)	48
13.3.1 1/1 spectrum analyser mode functions	48
13.3.2 1/1 spectrum analyser mode prior adjustments	49
13.3.3 1/1 spectrum analyser mode screens	49
13.4 1/3 spectrum analyser mode (OPTIONAL)	52
13.4.1 Spectrum analyser mode 1/3 functions	53
13.4.2 1/3 spectrum analyser mode prior adjustments	53
13.4.3 1/3 spectrum analyser mode screens	53
13.5 Octave (1/1) and third octave (1/3) band reverberation time (interrupted noise method) modes (OPTIONAL)	57
13.5.1 Octave (1/1) and third octave (1/3) band reverberation time (interrupted noise method) mode functions	57
13.5.2 Taking a measurement in octave (1/1) and third octave (1/3) band reverberation time (interrupted noise method) modes	58
13.5.3 Screens in the octave (1/1) and third octave (1/3) band reverberation time (interrupted noise method) modes	59
13.6 Octave (1/1) and third octave (1/3) band reverberation time (integrated impulse response method) modes (OPTIONAL)	62

13.6.1 Octave (1/1) and third octave (1/3) band reverberation time (integrated impulse response method) mode functions	63
13.6.2 Taking a measurement in octave (1/1) and third octave (1/3) band reverberation time (integrated impulse response method) modes	63
13.6.3 Octave (1/1) and third octave (1/3) band reverberation time (integrated impulse response method) mode screens	65
13.7 Occupational noise mode (OPTIONAL)	68
13.7.1 Occupational noise mode functions	68
13.7.2 Occupational noise mode prior adjustments	68
13.7.3 Occupational noise mode screens	69
13.8 FFT frequency analyser mode (OPTIONAL)	71
13.8.1 Taking an FFT measurement	71
13.8.2 FFT frequency analysis mode screen	72
13.9 Audio recording mode (analysis quality) (OPTIONAL)	73
13.9.1 Making an audio recording (analysis quality)	73
14. Advanced options	75
14.1 Zoom	75
14.2 Backerase	76
14.3 Marking	77
14.4 Voice comments	78
14.5 Audio recording (listening quality)	79
14.6 Automatic settings: Timers and triggers	80
14.6.1 Start measurement/recording automatically	80
14.6.2 Automatically stop measuring/recording	81
14.6.3 Automatic audio recording	83
14.6.4 DEN intervals	84
14.6.5 Examples of automatic measurement settings	85
15. Settings and adjustments	90
15.1 Accessing the settings sub-menu	90
15.2 Navigating through the settings sub-menu	90
15.3 Settings sub-menu	91
15.3.1 MEASUREMENT option 	91
15.3.2 RECORDING option 	93
15.3.3 AUTOMATISMS option 	95
15.3.4 DATE AND TIME option 	98
15.3.5 MICROPHONE SETTING option 	98
15.3.6 CONTRAST option 	100
15.3.7 AC OUTPUT option 	100
15.3.8 BLUETOOTH® wireless communication/PRINTER option 	101
16. Registers and memory management	102

16.1 Saving a final result	102
16.2 Making a recording	105
16.2.1 Types of recording	105
16.3 Structure of a register	111
16.4 Viewing and deleting registers	112
16.4.1 Viewing registers	113
16.4.2 Deleting registers	114
16.5 Deleting the card memory	114
17. Using the inputs and outputs	115
17.1 Digital inputs and outputs and AC output	115
17.1.1 AC Output	115
17.1.2 Digital input	116
17.1.3 Digital output	116
17.2 Communicating with a PC, downloading data and communicating with a printer	117
17.2.1 Memory card	117
17.2.2 RS-232 communications	118
17.2.3 USB communications	119
17.2.4 Bluetooth® wireless communication	119
17.3 PC software	120
18. Accessories	121
18.1 Accessories supplied	121
18.2 Optional accessories	121
19. Technical specifications	123
19.1 REFERENCE CONDITIONS	123
19.2 MICROPHONES AND PREAMPLIFIERS	124
19.2.1 Microphone models and their main features	124
19.2.2 Sound field correction for periodic tests	124
19.2.3 Frequency response	129
19.2.4 Directional response	135
19.2.5 Effect of the optional accessories on the microphone	136
19.2.6 Preamplifier connector	137
19.3 MEASUREMENT	137
19.3.1 Warm-up time	137
19.3.2 Measurement range	138
19.3.3 Linearity range	138
19.3.4 Noise	139
19.3.5 Information for testing compliance withdrawn standards IEC 60651 and IEC 60804	140
19.3.6 Time and clock features	141
19.3.7 Frequency weighting	141
19.4 CALIBRATION	142
19.5 OCTAVE AND THIRD OCTAVE BAND FILTERS	143
19.5.1 Octave and third octave band filters	143

19.5.2 Measurement range (octave band spectrum analyser)	144
19.5.3 Measurement range (third octave spectrum analyser)	145
19.6 REVERBERATION TIME	146
19.6.1 Measuring the decay curve and impulse response	146
19.6.2 Calculating the decay curve from the impulse response	146
19.6.3 Estimating the slope of the decay curve	146
19.6.4 Reverberation time measurement lower limit	146
19.6.5 Quality indicators	146
19.6.6 Lower limit for reliable results obtained through a filter and a detector	146
19.7 FFT	147
19.8 AUDIO RECORDING	147
19.9 ENVIRONMENTAL, ELECTROSTATIC AND RADIO FREQUENCY CRITERIA	148
19.9.1 Stabilisation time	148
19.9.2 Environmental criteria	148
19.9.3 Electrostatic criteria	148
19.9.4 Criteria for fields at the frequency of the mains supply and radio frequency fields	148
19.9.5 Influence of vibrations	149
19.10 INPUTS AND OUTPUTS	150
19.10.1 AC Output	150
19.10.2 Digital output	151
19.10.3 Digital input	151
19.10.4 MicroSD memory card slot	152
19.10.5 USB communication	152
19.10.6 RS-232 serial communication	152
19.10.7 Wireless communication	152
19.11 SCREEN	152
19.12 POWER	153
19.12.1 Batteries	153
19.12.2 External Supply	153
19.13 DIMENSIONS AND WEIGHT	153
19.14 STANDARDS	153
19.14.1 Standards	153
19.14.2 Standards of measurement and calculation	154
19.14.3 Certificates	154
19.14.4 Notes	154
20. Maintenance and precautions	155
21. Guidance on taking measurements	157
22. Activating optional modes	158
23. Functions	159
23.1 Function nomenclature	159

23.1.1 Sound level meter mode functions	159
23.1.2 1/1 spectrum analyser mode functions	161
23.1.3 1/3 Spectrum analyser mode functions	162
23.1.4 Octave (1/1) and third octave (1/3) band reverberation time mode functions	164
23.1.5 Occupational noise mode functions	165
23.1.6 FFT analyser mode functions	165
23.2 Function description	166
23.2.1 Sound pressure level with Fast and Slow time weightings	166
23.2.2 Sound pressure level with Impulse time weighting	167
23.2.3 Peak sound pressure level	167
23.2.4 Equivalent continuous sound pressure level	167
23.2.5 Taktmaximal-Mittelungspegel	168
23.2.6 Sound exposure level (SEL)	168
23.2.7 Percentile levels	169
23.2.8 Decay curve	169
23.2.9 Impulse response	169
23.2.10 Integrated impulse response method	169
23.2.11 Reverberation Time	169
23.2.12 Quality parameters (ξ , C and B·T values)	170
23.2.13 Equivalent daily noise exposure level	171
23.2.14 Sound exposure	171
23.2.15 Dose	171

This manual contains all the information you will need to get the most out of the device you have just purchased.

This information is divided into 7 sections:

The **first** section has chapters on the main features of the device and its physical components (chapters 3, 4, 5, 6, 7 and 8).

The **second** presents how the device can be used to take measurements, whether in sound level meter mode, spectrum analyser mode, reverberation time mode, etc. (chapters 9, 10, 11, 12 and 13).

The **third** section presents the device's range of advanced options, which make this a versatile tool that closely adapts to the needs of each user (chapter 14).

The **fourth** section focuses on configuring the device: menu structure and directions for carrying out the various adjustments (chapters 15 and 16).

In the **fifth** section, other important topics are covered, such as connecting to a PC, accessories (chapters 17 and 18).

The **sixth** section contains the technical specifications that explain the equipment you are working with in detail (chapter 19).

Finally, the **seventh** section encompasses several chapters that provide information such as: Maintenance and precautions, guidance on taking measurements, function nomenclature and descriptions, etc. (chapters 20, 21, 22 and 23).

NOTE: If you are already familiar with the device and only wish to consult the information on taking measurements, please see chapters 9, 10, 11, 12 and 13.

The first step is to check that all the equipment and literature supplied with the device is there:

Material:

- *SC420* sound level meter
- *PV009* windscreen
- Two AA size 1.5 V alkaline batteries (LR6)
- *CN400* USB-to-micro-USB cable for communication with a PC
- MicroSD memory card
- PC communication software to download, display and edit data: **CESVA Lab**

Literature included:

- Sound level meter user's manual
- Warranty

Should any of these elements be missing, please contact your official distributor.

This chapter provides a general description of the *SC420* sound level meter. This description will introduce you to all the possibilities offered by the *SC420* and its main features. It will also help you to identify the various components of the device.

3.1 *SC420* sound level meter spectrum analyser

The *SC420* is more than a sound measuring instrument — it is the ideal tool for the noise professional thanks to its high capacity, versatility and ease of use.

The *SC420* is a sound level meter that meets the specifications of IEC 61672 international standard for class 1 (see table) for both response to sound waves incident on the microphone in the reference direction in a free field and for response to randomly incident waves in a diffuse field (sound field correction configured for diffuse field).

The *SC420* also meets American standards ANSI S1.4 and ANSI S1.43, as class 1 (see table), for sounds from several angles (sound field correction configured for diffuse field):

MICROPHONE	ASSOCIATED PREAMPLIFIER	CLASS according to IEC 61672-1 and ANSI
C-130	PA020	1
C140	PA020	1
C240	PA040	1

The basic version of the *SC420* disposes the SOUND LEVEL METER measurement mode. It also offers the possibility of extension with different modules:

- Real time spectrum analyser module in octave bands (1/1) with class 1 filters as per standard IEC 61260
- Real time spectrum analyser module in third octave bands (1/3) with class 1 filters as per standard IEC 61260
- Reverberation time measurement (interrupted noise method) module (in 1/1 octave and third octave 1/3 bands)
- Reverberation time measurement (integrated impulse response method) module (in 1/1 octave and third octave 1/3 bands)

- Occupational Noise functions evaluation module
- FFT narrow band frequency analysis module
- Analysis quality audio recording module

When used with the appropriate modules, the *SC420* is a sound level meter that you can use to take any kind of measurement: measurements of acoustic insulation and reverberation time in buildings, measurement of environmental parameters (tonal, impulsive and low frequency components), analysis of industrial noise produced by machinery, exposure noise evaluations, etc.

Its ergonomic form means it can be used as both a hand-held instrument for in-situ measurements and as a device for carrying out continuous noise monitoring.

The *SC420* has advanced features such as: audio recording for recognition and reanalysis, automatic start and stop functions for measuring and audio recording by timers and threshold, extendible memory through cards, Backerase, USB connectivity, Bluetooth® wireless communication and 3G, ADSL, Wi-Fi communication capabilities, etc.

3.2 Main features of the *SC420*

The *SC420* it is a high performance sound level meter with the following main features:

THE **CESVA** PHILOSOPHY:

- The *SC420* keeps the **CESVA** philosophy of producing instruments that are powerful, simple and easy to use.
- Single range: no need for prior configuration of the *SC420* measurement range to match the dynamic range of the sound event to be measured.
- In each of its modes, the *SC420* measures all functions simultaneously. There is no need to configure time weighting or frequency weightings (A, C or Z).
- The *SC420* measures on three different time bases simultaneously: global values corresponding to the total measurement time (t), time history of consecutive partial values (T) configurable to between 1 second and 1 hour, and "Short Leq" time history every 125 ms. When measuring decay curves for reverberation time evaluation, a basis of 10 ms is used.
- This is all you need to do **ON & PLAY** measurements: Switch on and measure. At the touch of just two buttons, the *SC420* measures all the required parameters.

BACKERASE:

- With the Backerase option, the *SC420* can delete the last 10 seconds of the measurement in progress. This option is ideal when unwanted noise events occur during measurement (see 14.2).

The Bluetooth trademark is the property of Bluetooth SIG, Inc.

MARKS:

- This option allows the user to identify different stretches during measurement; this is a great help during post-processing since it means you can go directly to the stretches marked during the measurement (see 14.3).

microSD CARDS and DOWNLOADING DATA:

- Data measured by the SC420 can be saved on removable microSD cards (see 20), thus creating greater flexibility in data storage. The functions stored are configurable and the recording mode can be adapted to the type of measurement to be taken (see 15.3.2).
- The SC420 has **CESVA Lab** software that allows you to download any data recorded to a PC, in order to have them available in electronic format and export them to other programmes to create your own reports (see 17.3).
- Downloading data using **CESVA Lab** can be done simultaneously with the measurement or recording processes. This feature, together with the option to erase measurement periods as they are downloaded, makes the SC420 the perfect platform for permanent acoustic monitoring (see 17.2).
- You can also remove the microSD card, insert it into a PC and import data using the **CESVA Lab** software. While the full card downloads, the SC420 can continue saving results on a new card. This is an alternative way to take long measurements without loss of data (see 17.2.1).
- The file system used by the SC420 is optimised for downloading large amounts of data, optimising the download time and facilitating the resumption in case of failure of the communication channel.

INNOVATIVE DESIGN:

- The ergonomic shape of the SC420 has been designed to minimise the effects of any reflections or diffractions and provide a comfortable and firm grip.
- The 3.2" graphic display allows data to be shown both numerically and graphically. The graphic display is highly practical when it comes to studying a sound event, evaluating its time history or analysing its spectral content. It also has an automatic zoom option for looking at highly stable noise events in more detail (see 14.1). The SC420's screen can be read clearly and precisely in full daylight; it can also be illuminated at the touch of a button, allowing the user to work in low-light conditions as well.
- The SC420 has an intuitive keypad with four keys dedicated to the main functions, four contextual keys (softkeys) that adapt to the information displayed on the screen and four selector keys (joystick) to facilitate navigation through its menu structure (see 5).
- The SC420 supports both prepolarised and polarised 200 V microphones. Each type of microphone needs its corresponding preamplifier. These can be removed in order to attach CN003, CN010 or CN030 extension cables or TK200 outdoor kit for measurements taken outside (see 8).

ICON MENU:

- The device is configured using menus composed entirely of easily identifiable and recognisable icons, with no need to set languages.

AUDIO RECORDING, TIMERS AND TRIGGERS:

- While it is taking measurements, the *SC420* can also record audio files for recognition of sound sources (listening quality) (see 14.5), for voice comments (see 14.4) and for post-processing (quality analysis) (see 13.9).
- The *SC420* has a complete system of automatic settings for starting and stopping measurement and audio recording using automatic timers and triggers activated by exceeding the threshold by time intervals. This extends even further more the possibilities of the *SC420* as a stand-alone unit for continuous noise monitoring (see 14.6).
- The power for environmental monitoring option allows the *SC420* to resume recording after recovering from a power cut (see 7.3).

COMMUNICATIONS:

- The *SC420* can communicate with a PC via a USB port, Bluetooth® wireless communication or RS232 serial port for downloading data, programming or control and visualisation in real time. Communication is also possible via 3G, ADSL and Wi-Fi (see 17.2).
- The RS232 port of the *SC420* can be configured to connect a serial printer. In SLM mode and octave 1/1 band spectrum analyzer mode, the *SC420* sends in real-time the values of the measured functions (see 17.2.2).
- The *SC420* has a multi-contact connector which makes available: the AC signal from the microphone, the digital inputs and outputs for control and the RS-232 serial communication port (see 17).

LOG OF CHANGES:

- Saved in its memory, the *SC420* has a log of the last five modifications of changes to date and time and adjustment of sensitivity, with the date and time when they were carried out.

3.3 Device components

The following diagram shows the main components of the SC420:

1. **½" precision condenser microphone** - The SC420 complies as class 1 (see 3.1).
2. **Preamplifier** - The preamplifier on the SC420 is removable and should match the preamplifier model associated with the microphone (see 3.1). The preamplifier is connected using the LEMO connector (3).
3. **Preamplifier LEMO-type connector** - LEMO-type male connector or the preamplifier. This is protected by the protective cone.
4. **Sound level meter LEMO-type connector** - LEMO-type female connector for the sound level meter of the SC420. This is protected by the protective cone.
5. **Protective cone** - Cone that covers the female sound level meter and the male preamplifier LEMO connectors to protect them.
6. **Screen** - Large 3.2" backlit LCD graphic screen.
7. **Membrane keypad** - Extra flat keypad that minimises reflection.
8. **Manufacturer information** - Area where the brand origin of design and manufacture are indicated.
9. **IEC marking** - This area displays the sound level meter model and serial number, as well as the IEC standards that it meets.
10. **Space reserved for the periodic test label** - Space reserved for the label of compliance with the sound level meter periodic test (as per IEC 61672-3).
11. **Class information** - This area displays the classification of the sound level meter in terms of compliance with the standards specified in the IEC and ANSI marks, depending on the microphone.
12. **ANSI mark** - Area that indicates the ANSI standards met by the SC420.
13. **Tripod support** - Flush tripod support with ¼" W standard thread. (TR040 and TR050).
14. **WEEE marking** - Indicates the separate collection of electrical/electronic appliances.
15. **CE marking** - European conformity mark.
16. **Protective battery cover** - Protective battery cover: only remove to change batteries.
17. **Bluetooth symbol** - The SC420 has Bluetooth® wireless communication.
18. **Protective connector cover** - Cover to protect the connectors from possible damage.
19. **USB connector** - Micro-B USB connector for digital communication and power. Complies with USB rev. 2.0.
20. **Memory card slot** - Slot for microSD memory cards.
21. **Multi-connector** - This connector has different inputs/outputs (AC output, digital input/output and RS-232 serial port).

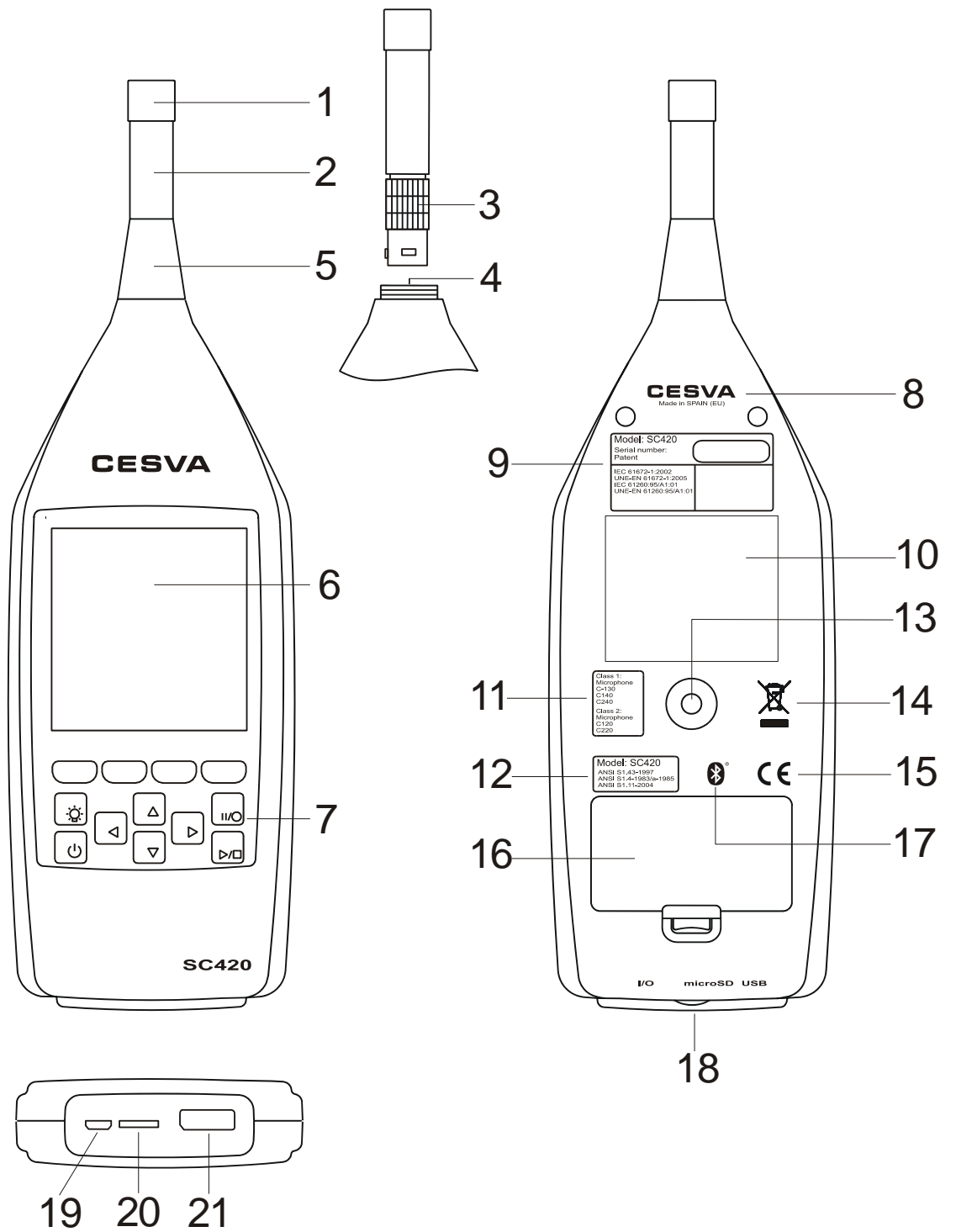

This chapter describes the digital and analogue inputs and outputs of the *SC420*. It describes how to identify and configure them, and how to extract data and signals from them.

The *SC420*'s inputs and outputs are on the bottom of the device, protected by a removable protective cover. To access them, lift the cover, remembering to put it back once you have finished.

4.1 *SC420* inputs and outputs

The *SC420* has the following inputs and outputs:

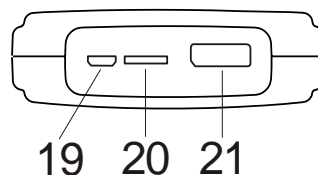

1. **USB [19]:** Input/output for two-way digital USB communication with a PC and for powering the device. Complies with USB rev. 2.0. To connect the *SC420* to a PC through this input, use cable CN400.
2. **Memory card slot [20]:** Slot for a microSD memory card. The data recorded by the sound level meter, functions and audio are stored on this card. Larger capacity cards can cause permanent damage to the device (see 20).

NOTE: For the device to function correctly, you should use at least a class 4 card. The card class determines the write speed; therefore, the higher the card class is, the faster the *SC420* will work.

3. **Multi-connector [21]:** (Twenty-contact connector with various inputs and outputs. To access these inputs and outputs, use *CN420* cable:
 - **RS-232 serial port.** Input/output serial port for two-way digital communication with a PC (see 4.2).
 - **AC output.** Analogical output directly proportional to the preamplifier output, without frequency weighting (see 4.3).
 - **Digital output.** Digital output that takes values depending on whether the automatic audio recording threshold is exceeded (see 4.4).

- **Digital input.** Digital input that enables a measurement to be started or stopped and marks to be inserted, depending on its state (see 4.4).
4. **Bluetooth® wireless communication.** Wireless input/output for two-way digital communication with a PC via radiofrequency (see 4.2)

4.2 Communications inputs and outputs

The SC420 can communicate with a PC via the **CESVA Lab**, USB, Bluetooth® wireless communication or the RS-232 serial port. The SC420 allows the connection to a serial printer too (see 17.2).

To use the RS-232 serial input/output, use the CN420 cable, inserting the cable's male multi-connector into the female SC420 multi-connector. On the RS-232 SERIAL connector, at the opposite end of the cable, you will find this input/output.

It is also possible to communicate via 3G, ADSL and Wi-Fi: for more information, please consult your official **CESVA** distributor.

4.3 AC Output

The AC output contains an alternating current signal proportional to the output of the preamplifier. This makes it possible to:

- Listen to the sound event being measured and determine whether it is influenced by noises other than those that you wish to measure.
- Physically record said signal for recognition of the sound event being measured or for reanalysis of the signal received by the microphone. This option is possible using the SC420 itself (see 17.1.1).

To extract the aforementioned signal, use the CN420 cable, inserting the cable's male multi-connector into the female SC420 multi-connector. The AC OUTPUT connector has the AC output at the opposite end of the CN420 cable.

In order to adapt the dynamic range of the AC output to the hearing or recording range, use the  option in the CONFIGURATION menu (see 15.3.7).

4.4 Digital inputs and outputs

The SC420 has a digital input and a digital output. To work with them, use the CN420 cable, inserting the cable's male multi-connector into the female SC420 multi-connector. You will find them on connectors DIGITAL I and DIGITAL O respectively, at the opposite end of the CN420 cable.

The digital output takes values depending on whether the automatic audio recording threshold is exceeded in each of the time zones. If the threshold is exceeded, the signal in the digital output takes value 0; if it is not exceeded, the value is 1 (see 17.1.3).

The digital input can start and stop a data recording depending on its state. The START AUTOMATIC MEASUREMENT and STOP AUTOMATIC MEASUREMENT options should be activated and configured with the DIGITAL INPUT option (see 17.1.2). This input can also be used to insert markers while recording data (see 14.3).



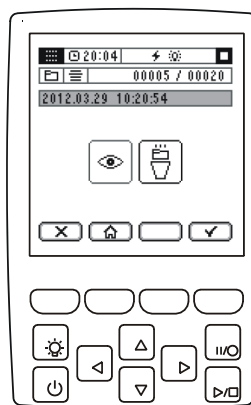

This chapter describes the keys that make up the SC420 keypad, its typology and its functions.



The SC420 has an intuitive keypad with twelve keys: four dedicated keys, four contextual keys (softkeys) and four selector keys (joystick).

DEDICATED KEYS:

These are the keys associated with the main actions, because of their importance and the need to access them at any moment.

KEY	FUNCTION
 POWER	Key to switch the SC420 on and off. The sound level meter cannot be switched off when a measurement or recording is in progress
 LIGHT	Key to temporarily or permanently switch the screen lighting on (see 9.3). Using the screen light reduces the instrument's battery life
 PLAY/STOP	Key to start and stop a measurement or resume after a pause
 PAUSE/REC	Key to temporarily stop a measurement (pause) or start a recording

CONTEXTUAL KEYS (SOFTKEYS):



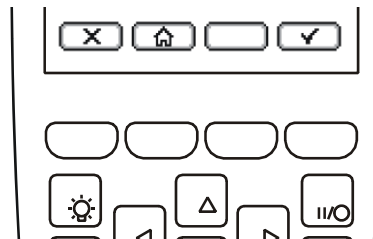

Most actions on the SC420 are performed using the 4 contextual keys (softkeys). The functions of these keys vary according to the indication that appears in the lower part of the screen, just above each key.

The contextual keys (softkeys) adapt to each measuring mode and display screen, as well as to the kind of information displayed. Therefore, in this area, only the actions specific to each screen will be accessible.



SELECTOR KEYS (JOYSTICK):

The selector keys (joystick) enable navigation through the menu structure of the SC420 and speed up configuration of parameters and options as well as the change between the different measurement modes.

KEY	FUNCTION
 UP	Key to move upwards
 RIGHT	Key to move towards the right
 LEFT	Key to move towards the left
 DOWN	Key to move downwards

The selector keys can also be used for specific actions during the measurement process (see 11).

Screen | 6

This chapter describes the features of the screen and the information it displays.

The SC420 has a 3.2" backlit screen that can display both graphic and numerical data.

The SC420's screen is divided into 5 areas; the information that appears on each of these is presented below.

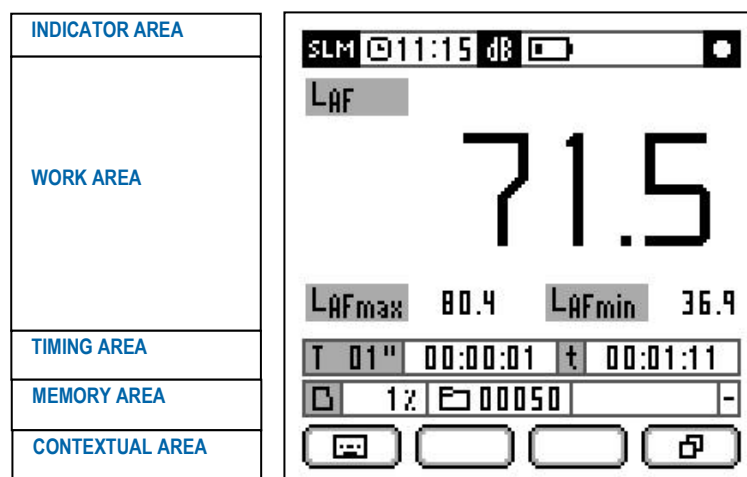





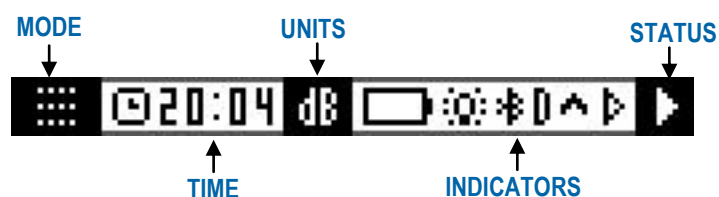





6.1 Indicator area

This area is the most important, since it provides essential information for the user. It is always visible, although the information that appears on it may vary depending on the measurement in use, the configuration of the SC420 and the state of measurement.



MODE:

The mode indicator is the most important as it tells us if we are on the configuration menu or indicates the current measuring mode.

INDICATOR	SITUATION
	Menu
	Sound level meter mode
	1/1 octave band spectrum analyser mode
	1/3 octave band spectrum analyser mode
	1/1 octave band reverberation time measurement mode (interrupted noise method)
	1/3 octave band reverberation time measurement mode (interrupted noise method)
	1/1 octave band reverberation time measurement mode (integrated impulse response method)
	1/3 octave band reverberation time measurement mode (integrated impulse response method)
	Occupational noise functions mode
	FFT frequency analysis mode
	Audio recording mode for reanalysis

To change mode (see 13.1)

TIME:





Shows the *SC420*'s current time (hh:mm:ss).

UNITS:

When measuring or displaying records, this indicates the units of the functions shown in the work area.

INDICATORS:

The indicators provide continuous information on various aspects of the *SC420*.

INDICATOR	INFORMATION
	Battery power and status (see 7.1)
	USB or A300 feeder power (see 7.1)
	Screen light permanently light (see 9.3)
	Bluetooth® wireless communication activated (see 15.3.8)

⚠	Overload (see 11.4)
🗉	Diffuse sound field correction (see 15.3.5)
▶	Automatic measurement start scheduled (see 15.3.3)
🕒	Automatic recording start scheduled (see 15.3.3)
🕒	Automatic measurement/recording end scheduled (see 15.3.3)

STATUS:

Displays the current measurement status of the SC420.

INDICATOR	SITUATION
🛑	Stopped
▶	Measurement in progress
🎙	Recording in progress
⏸	Measurement or recording temporarily halted (pause)
📄	Displaying a record

6.2 Work area

This area shows the value of functions during the measurement process or while displaying records, the various configuration options and parameters when accessing the menu, or standby information when there are scheduled automatic measurement or recording starts.

6.3 Timing area

This area is only visible in the measurement modes, both during a measurement and when displaying a record. It does not appear in the configuration menu.

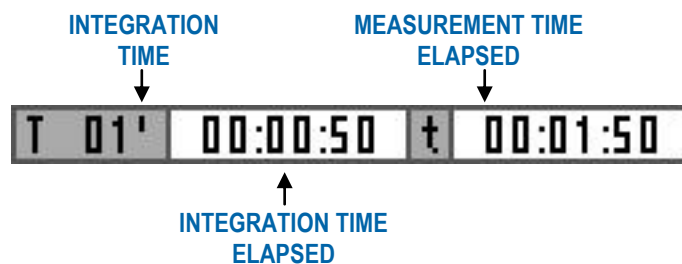

The timing area shows the following information:

- The integration time scheduled for the current mode (T)
- The integration time elapsed
- The measurement time elapsed (t)

6.4 Memory area

This area is only visible if there is a memory card inserted in the slot and if it is in a measurement mode, both during a measurement and when displaying a record. It does not appear in the configuration menu.

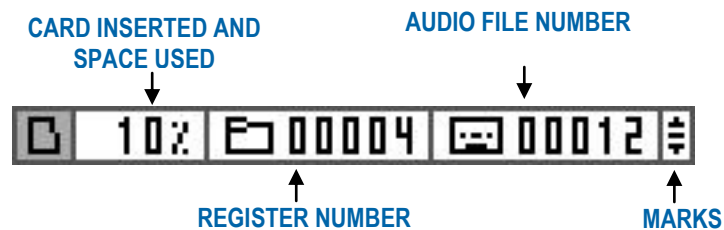

The memory area shows the following information:

- Memory card inserted indicator.
- Space used on memory card. 0%: card empty. 100%: card full.
- During a recording: the record number under which the information measured is being saved. When displaying a record: the number of that record.
- During a recording: The audio file number that is being stored associated with the current register (in the above image, audio file number 12 is being saved in register number 004 of the memory card).
- During a recording: if any mark is being used at that moment. There are up to three marks and each is indicated differently (see 14.3).

6.5 Contextual area

The actions associated with the four contextual keys can be accessed from this area.



Before turning the *SC420* on, the first thing to do is connect it to a power supply. This chapter describes the different ways of powering your device, as well as the configuration options that affect the power supply.



7.1 Power sources

The *SC420* can run on alkaline batteries, through a USB connection or using the *AM300* mains feeder.

7.1.1 Battery power

The *SC420* sound level meter is fed by two 1.5 V alkaline or lithium batteries sized AA (LR6) or through the USB port. If both systems are used at the same time (batteries + USB port), the *SC420* selects the one offering the higher voltage (only valid for  option, see 7.3).

To fit the batteries, lift the battery compartment lid at the rear of the *SC420*. Insert the two batteries as indicated in the diagram shown in the compartment.

When the batteries are fully charged, the  symbol is displayed on screen. As the batteries run down, the symbol becomes empty: . When the batteries are not sufficiently charged for the *SC420* to function correctly, the empty battery symbol with a cross through it  is displayed in the centre of the screen for two seconds; if there is a measurement or recording in progress, it will stop and the device will then shut down. The batteries should be replaced.

To replace the batteries, the device must be switched off. To remove the *SC420*'s batteries, open the battery compartment, press the battery against the spring and pull it upwards, holding the battery by its positive pole.

7.1.2 Power via USB

The *SC420* can also be powered through the USB port.

One option is to use a PC as a power source. Use cable *CN400* to connect the *SC420* USB port with a PC USB port. As you connect it, the  symbol will appear where the battery symbol was previously.

7.1.3 Mains feeder

Another option is to use the *AM300* mains feeder.

This feeder is connected to the mains supply and has a USB output for connecting the *CN400* cable and powering the *SC420*. The *AM300* mains feeder is an optional accessory.

RECOMMENDATIONS:

- When using an external power supply (USB or mains feeder) it is advisable to fit new batteries (see 7.3).
- If the *SC420* is not be used for some time, remove the batteries from the *SC420* to prevent damage caused by battery leakage.
- It is advisable to always carry spare batteries.

7.2 Energy saving

Using Bluetooth® wireless communication and the screen light considerably reduce battery life. If running the sound level meter exclusively on batteries, it is recommended that you:

- Use the screen lighting as little as possible (see 9.3).
- Disable Bluetooth® wireless communication when this not in use (see 15.3.8).

7.3 Power for environmental monitoring

This option is designed for using the *SC420* during particularly long recordings, for continuous monitoring. Activating this option () is recommended for such recordings, is recommended for this type of recording, so that when there is an external power supply failure during a recording, the *SC420* switches to battery power, halts the recording in progress and switches off automatically. When the external power supply recovers, the *SC420* will switch back on automatically and begin a new recording (with the same conditions as for the previous measurement process).

However, it is advisable to disable this option () for all other cases. Therefore, when an external power supply failure occurs during a recording, the device switches to battery power and continues with the measurement until it is manually stopped, the batteries run out or the mains power returns.

To activate and deactivate this option, please see 15.3.2.

NOTE: To ensure the device behaves as indicated above, it is essential that batteries are inserted.

This chapter explains how to fit the microphone and the preamplifier to the *SC420*, as well as all the accessories that can be used for the microphone: the windscreen, extension cable and outdoor kit.

8.1 Windscreen

In order to minimise noise effects produced by the wind, you can attach the **CESVA** PV009 model windscreen to the microphone, as shown in the figure below.

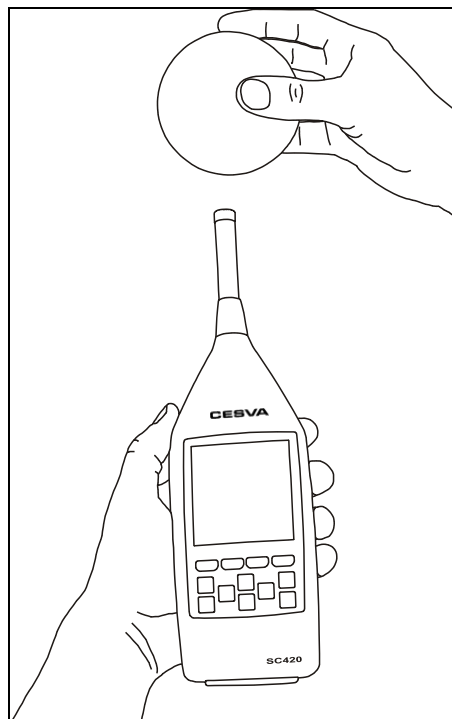

8.2 Extension cable

The SC420 microphone and preamplifier are removable. This allows the microphone to be moved away from the sound level meter and user. Therefore, the SC420 can be operated far from the point of measurement to avoid possible interference. To do this, you need to use one of the following **CESVA** extension cables: *CN003* (3 metres), *CN010* (10 metres) or *CN030* (30 metres).

The preamplifier and the microphone are an indivisible set, as the microphone is screwed into the preamplifier. Do not unscrew the microphone from the preamplifier unless it is strictly necessary; the microphone could be damaged during handling.

NOTE: **CESVA** accepts no responsibility for unauthorised modification, alteration or repairs carried out by unlicensed personnel; any such actions will invalidate the device warranty.

WARNING! When connecting or disconnecting the preamplifier or microphone, the sound level meter must be switched off.

WARNING! Do not attempt to attach or detach the preamplifier by screwing on or unscrewing the connector, as the sound level meter could be damaged.

8.2.1 Removing and connecting the preamplifier

To remove the preamplifier from the sound level meter, unscrew the protective cone, find the preamplifier LEMO connector and pull out the preamplifier connector as shown in the diagram. Do not pull on the preamplifier itself.

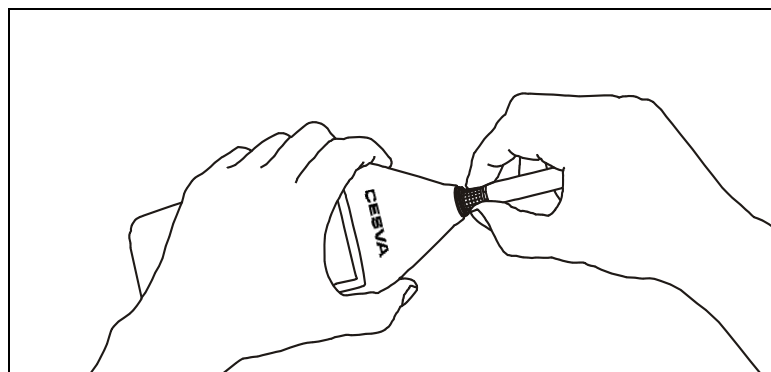

To reconnect the preamplifier to the sound level meter, firstly ensure you have inserted the preamplifier through the protective cone (pass the end of the preamplifier's LEMO connector through the narrower end of the protective cone). Next, using your fingers, insert the preamplifier's male LEMO connector into the sound level meter's female LEMO connector, ensuring the red dot on the preamplifier lines up with the red dot on the sound level meter connector, until you hear them click perfectly into place. Finally, screw on the protective cone.

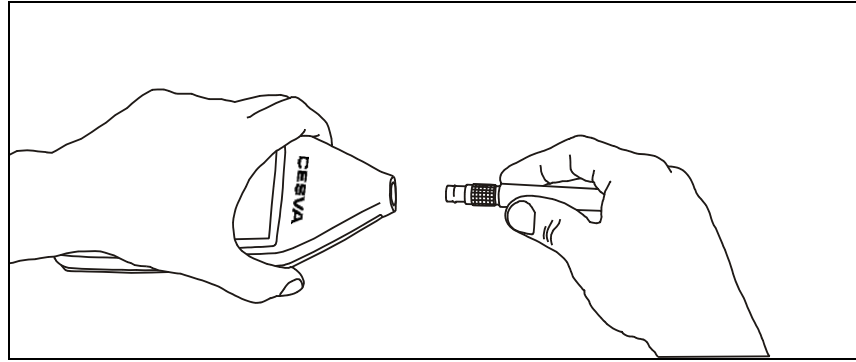

8.2.2 Connecting the extension cable

First, remove the preamplifier from the sound level meter. Pass the protective cone through the extension cable's male LEMO connector (the narrow part first). Insert the extension cable's male LEMO connector into the sound level meter's female LEMO connector until you hear them click perfectly into place. The red dots should line up. Then screw on the protective cone.

To attach the preamplifier + microphone to a tripod, use adaptor *TR001*. To do this, follow the steps detailed below:

1. Insert the extension cable's female LEMO connector through adapter *TR001*.
2. Insert the screwdriver through the bottom of adapter *TR001* and tighten the internal screw of the *TR001* so that the LEMO connector is fixed to the adapter.
3. Screw the adaptor onto the tripod.
4. Connect the preamplifier by inserting the preamplifier's male LEMO connector into the female extension cable connector until you hear them click perfectly into place. The red dots should line up.

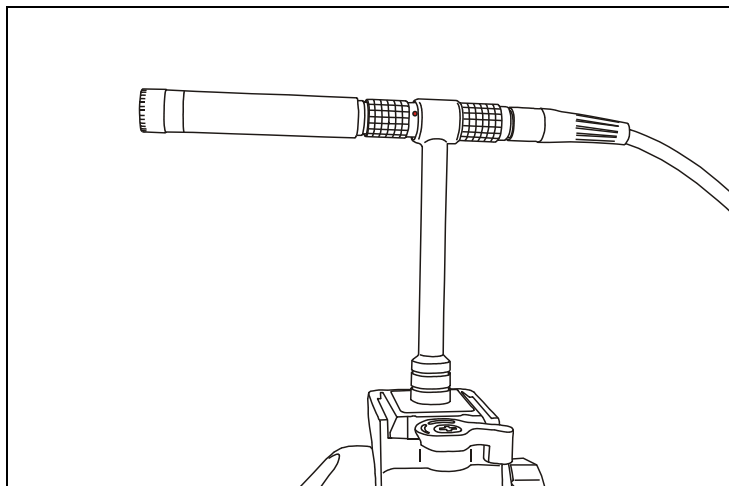

NOTE: The cables do not have any effect inside the measuring frequency band. A recalibration is not necessary when using the extension cables. The extension cables are an optional accessory and are not included in the normal operating mode.

8.3 Outdoor kit

You can complete your measuring instrument with the **CESVA TK200** model outdoor kit, designed to protect the preamplifier + microphone set from moderate wind and rain, birds, insects, humidity, etc. The outdoor kit includes a windscreen, rain protection, bird protection and dehumidifier.

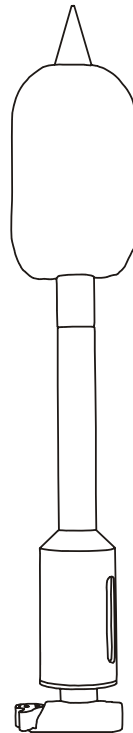

The *TK200* requires maintenance: please consult the instruction manual.

NOTE: The *TK200* outdoor kit is an optional accessory and is not included in the normal operating mode.

Switching the device on and off

9

This chapter explains how to switch the *SC420* and the screen light on and off.

9.1 Switching the device on



To switch on the *SC420*, press the  key; the device performs a self-check and then the **CESVA** logo appears on the screen together with the *SC420* model and the firmware version.

After a few seconds, the screen of the last measurement mode used will appear. If it is the first time you have used the *SC420* or the last time you used it was not in a measurement mode, the main menu  will appear.

At the same time, the egg timer symbol will appear, indicating that the sound level meter is not yet ready to take measurements. Therefore, it is not possible to begin taking measurements until this symbol disappears (approximately 15 seconds). It is, however, possible to access or navigate through the menu during this time.

NOTE: If the *SC420* does not switch on, check that it is correctly connected to a power supply.

The *SC420* can be switched on in two different ways:



1. By pressing , it will switch on normally.
2. By powering the *SC420* through the USB input, the sound level meter will switch on automatically without having to press .

9.1.1 Initial SC420 self-check

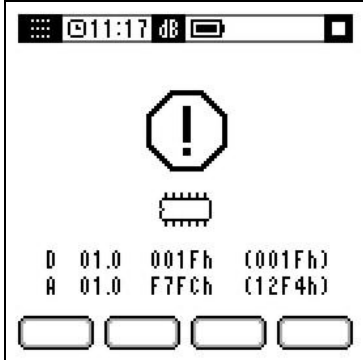
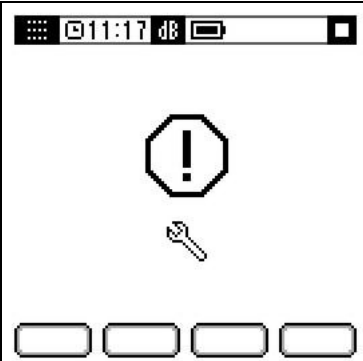
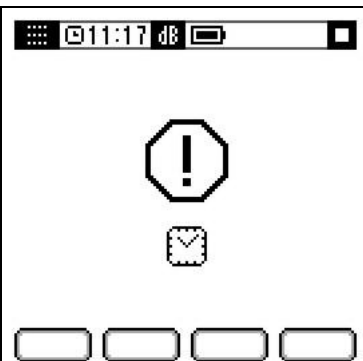
Should any error be detected during the SC420 initial self-check, an alert screen will be displayed. A description of each alert screen is given below, along with instructions for how to proceed should it appear:





SCREEN	REASON AND HOW TO PROCEED
	<p>A serious fault has occurred in the device and it is impossible to continue working with it.</p> <p>Switch the device off and contact your official CESVA distributor.</p>
	<p>There is a fault in one of the device's programming parameters.</p> <p>Press any key. SC420 will automatically assign the start-up value to this parameter and you will be able to continue working as normal. Review the programming.</p>
	<p>The date/time is incorrect.</p> <p>Press any key. SC420 will automatically assign a default date and you will be able to continue working. Review the date/time.</p>

9.2 Turning the device off

To turn off the SC420, check that no measurement is in progress  and press .

NOTE: Turning off the SC420 may take a few seconds. During this time, the hourglass symbol  will appear on the screen to indicate that all the data is being saved. This ensures a quick start up the next time the device is switched on.

9.3 Switching the light on and off

If the  key is pressed, the screen light comes on; it will go off automatically after 10 seconds have passed since the last key was pressed. If the  key is pressed for more than 2 seconds, the light stays on, the  symbol will appear in the indicators area (top right corner of the screen) and will only go off if the light on/off key  is pressed again.

NOTE: Using the screen light reduces the instrument's battery life.

Before and after a measurement, it is advisable to check the sound level meter with an acoustic calibrator. A measurement is considered valid if it takes place between two successful checks.

10.1 Checking the SC420

To check the *SC420*, use class 1 acoustic calibrator **CESVA** CB006 model and follow these steps:

Insert the *SC420* into the calibrator introducing the microphone into the cavity of the calibrator. Make sure the microphone reaches the bottom of the cavity and is parallel to the calibrator axis (see figure). This may require a little effort since the sound level meter must fit exactly into the calibrator. Insert the *SC420* gently; otherwise the microphone may be damaged.

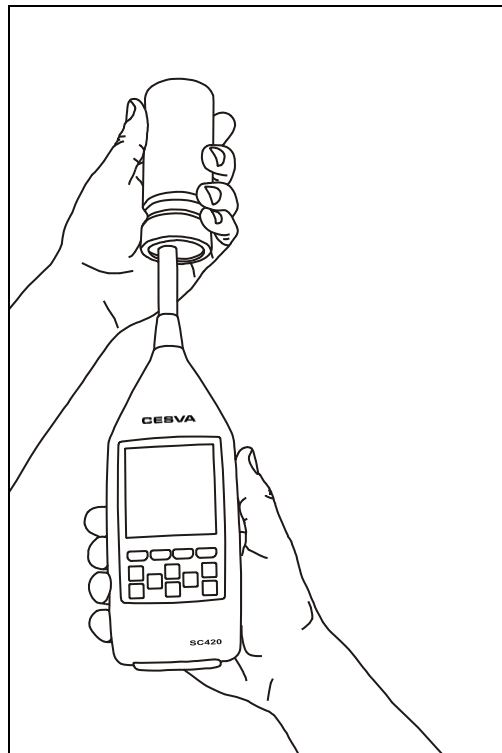

Turn the calibrator on and check the battery status. The indicator light must remain on throughout the calibration process (please see the calibrator manual). The calibrator generates a tone of 94 dB at 1 kHz.

Apply the free field pressure corrections of the microphone at 1 kHz. The free field pressure correction at 1 kHz of microphones **CESVA** C-130, C140 and C240 is -0,1 dB. That is, the SC420 should read 93.9 dB.

Switch the SC420 in numerical sound level meter mode (see 13.1).

Set the function to measure to sound pressure level with fast impulse time weighting (FAST) L_{AF} . The frequency weighting A makes no difference since calibration takes place at 1 kHz.

Start measuring with the SC420 in numerical sound level meter mode (see 11.2)

Check that the function value on the screen (L_{AF} , L_{CF} or L_{ZF}) coincides with the value of 94.0 dB corrected with the corresponding corrections (normally 93.9 dB).

If the value of the reading is within the range of ± 0.3 dB, the check has been successful. If that is not the case, the sensitivity of the sound level meter needs to be adjusted by authorised personnel.

NOTE: The sensitivity of the sound level meter must only be adjusted by authorised, technically qualified personnel. Readjustment of the sensitivity entails the loss of traceability in the calibration of the instrument.

CESVA assumes no responsibility for sensitivity adjustments performed by unauthorised personnel.

To adjust the sensitivity, please see 15.3.5

NOTE: Acoustic calibrator CB006 has internal static pressure compensation to maintain the level generated within tolerance limits between 65 kPa and 108 kPa of static pressure. Thus there is no need to make any additional correction.

The SC420 can be used to take measurements and make recordings⁽¹⁾ of acoustic functions:

- Manually: using the keypad.
- Automatically: Using the configuration option AUTOMATISMS/START RECORDING and AUTOMATISMS/END RECORDING, programming the levels and schedules to start and/or end recording.

⁽¹⁾ This chapter does not refer to the reverberation time, audio recording or FFT narrow band frequency analysis modes. For information on taking measurements in one of these modes, please see 13. Please note that automatic measurements are not possible in these modes.

This chapter describes the basic steps to take a measurement and make a recording manually. For automatic measurements/recordings, please see 15.3.3.

IMPORTANT: The difference between a MEASUREMENT and a RECORDING is that with a measurement the parameters being measured are displayed on the screen and once the device is turned off, the data are lost. However, with a recording, as the parameters are being measured, the data are also saved in the memory of the SC420. Thus, if the device is turned off, the data are preserved.

At the end of a RECORDING, the time history of the functions measured and the final results will be saved in a register. At the end of a MEASUREMENT, nothing will have been saved and it will only be possible to save the final results of the measurement by using the option SAVE RESULTS; the time history can never be saved.



11.1 Prior steps

Once the SC420 is switched on and the device has been checked (see 10.1), ensure that there are no measurements in progress . To continue, select the mode in which you wish to carry out the measurement and make the prior adjustments (see 13).







11.2 Taking a measurement

Once in the desired measurement mode, press the  key to start a measurement.

During the measurement, the following information will appear on the screen:



- INDICATOR AREA: ongoing measurement indicator ; indication of the units of the functions that appear in the work area; indication whether an overload has occurred during measurement .
- WORK AREA: Functions corresponding to the screens of the chosen measurement mode.
- TIMING AREA: The scheduled integration time (T), the integration time elapsed and the measurement time elapsed (t).

Once the measurement has started, you can:

- Momentarily stop the measurement with the  button. The status indicator will change to measurement temporarily paused .
- End the measurement by pressing . The status indicator will change to measurement ended .
- Use the graphic screens for an automatic zoom of the data displayed on the screen by pressing  or return to the display of the full range by pressing  (see 14.1).

NOTE: The function values are refreshed on the screen every second.

If the measurement has been stopped momentarily , the device enables you to:

- Perform a Backerase of the last 10 seconds by pressing  (see 14.2).
- Resume the measurement, by pressing . While a measurement is stopped, the measurement time elapsed is paused.

11.3 Making a recording

IMPORTANT: Ensure a microSD memory card is inserted in the slot. You can check this by ensuring the memory card symbol is displayed in the memory area of the screen. If there is no card, it will be impossible to start a recording.







Once in the desired measurement mode, start recording by pressing .

NOTE: If it is a recording in sound level meter mode, spectrum analyser in octave bands mode or spectrum analyser in third octave bands mode, the frequency and the functions that the SC420 will store the while recording will appear on screen for 3 seconds, before recording starts.



During the recording, the screen will display the following information, in addition to the measuring information:



- INDICATOR AREA: recording in progress indicator .
- MEMORY AREA: Memory space used; current register number.

Once the recording has started, you can:

- Momentarily stop the recording with the  button. The status indicator will change to recording temporarily paused .
- End the recording by pressing . The status indicator will change to recording ended .
- Use the graphic screens for an automatic zoom of the data displayed on the screen by pressing  or return to the display of the full range by pressing  (see 14.1).
- Initiate an audio recording of 15 s (5 s prerecording and 10 s recording) by pressing  (see 14.5). During a recording, the screen will display the audio file number being saved associated with the current record.

If the recording has been stopped momentarily , the device enables you to:

- Perform a Backerase of the last 10 seconds by pressing  (see 14.2).
- Resume the recording, by pressing . While a recording is stopped, the measurement time elapsed is paused.

NOTE: While the SC420 is in , audio recordings can be made (see 14.5) and while it is in , the Backerase function can be used (see 14.2).

11.4 Overload indicator

The SC420 is equipped with an overload indicator for each function. If an overload occurs during a measurement, the  indicator will be added in front of the function value that has been affected. When a function registers overload, its corresponding measurement will be incorrect.

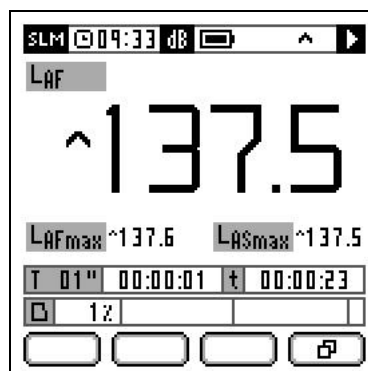

During the overload, the  symbol will be displayed in the indicator area.

NOTE: If overloading occurs while the SC420 is conducting a quality analysis audio recording (optional), the 🗨️ indication will be displayed in the indicator area while overload occurs and the 🗨️ indication will be shown beside the progress bar when the recording ends.

11.5 Under-range indicator

The SC420 is equipped with an under-range indicator for each function. If the value displayed on-screen is under the lower limit of the range of linearity, the ⚡ indicator will appear in front of the value of the function affected. This indicator only appears while this condition remains.

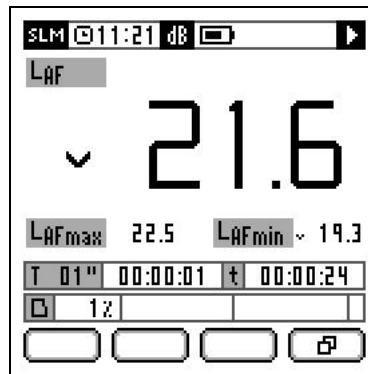



When a function has recorded under-range, this indicates that it is a limit of the measurement.



The SC420 menu allows you:

- Save final results and manage the memory and the saved registers
- Configure SC420 adjustments
- Select the measurement mode
- Record voice comments (see 14.4)

12.1 Accessing the menu

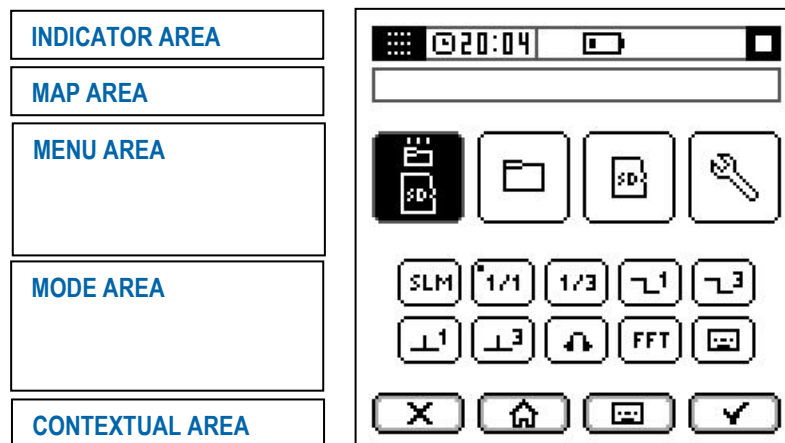
Once the SC420 is switched on, ensure there is no measurement in progress  and press . The main menu screen  is displayed automatically.



- The cursor (highlighted option) will be at the first option in the menu area. Press   to select any option in the menu area.
- Press  to access the current mode in the mode area.

12.2 Menu areas

The SC420 menu screen features the following areas:

- **INDICATOR AREA:** Shows essential information for the user (see 6.1).
- **MAP AREA:** Indicates, with icons, the current location within the different menu screens of the SC420.
- **MENU AREA:** Shows the options available on the current menu screen (indicated in the map area) of the SC420.
- **MODE AREA:** Shows the measurement modes available on the SC420 and identifies the current mode with a dot. Only available on the main menu screen of the SC420.



- **CONTEXTUAL AREA:** Shows the actions available on the four contextual keys.

12.3 Navigating through the menu

To select an option from the menu area, to select a measurement mode or to change between the menu and mode areas, use the selector keys .

Pressing accepts the option or the mode selected.

Pressing takes you to the previous menu screen.

Pressing takes you directly to the current measurement mode, without accepting the selected action.











The basic version of the *SC420* disposes the SOUND LEVEL METER measurement mode. It is also possible to purchase optional modules to activate other more specific measurement modes and thus increase the *SC420* applications. These modules can be purchased when the user needs them, so that you are only working with the modes that you really need.

This chapter describes all the features (parameters measured, display screens, options available, etc.) of each of the *SC420* measurement modes.

13.1 Selecting the measurement mode



When you switch the sound level meter on, the screen of the last measurement mode that was used is displayed. This could be any of the modes available on the *SC420*.







The measurement modes are as follows:



-  Sound level meter mode
-  OPTIONAL octave band spectrum analyser mode
-  OPTIONAL third octave band spectrum analyser mode
-  OPTIONAL octave band (1/1) reverberation time mode (interrupted noise method)
-  OPTIONAL third octave band (1/3) reverberation time mode (interrupted noise method)
-  OPTIONAL octave band (1/1) reverberation time mode (integrated impulse response method)
-  OPTIONAL third octave band (1/3) reverberation time mode (integrated impulse response method)
-  OPTIONAL occupational noise mode functions
-  OPTIONAL FFT frequency analyser mode
-  OPTIONAL audio recording mode for reanalysis

To identify which mode the *SC420* is in at any moment, simply look at the indicator in the top left-hand corner of the screen, in the indicator area.

To select the mode to be worked in, proceed as follows:

- Press 
- The main menu screen  is displayed automatically (see 12.1).

- The cursor (highlighted option) will be at the first option in the menu area.
- Press  to access the mode area.
- Next, using the selector keys     select the desired measurement mode.
- Finally, press 

NOTE: While the SC420 is in , you can return to the main menu screen by pressing , whatever the mode the device is currently in.

13.2 Sound level meter mode

The sound level meter mode is suitable for measuring overall sound pressure levels, both instantaneous and averaged based on integration (equivalent level). The SC420 measures all functions simultaneously with all frequency weightings (A, C and Z) and calculates statistical data, such as maximum and minimum values and percentiles. It also measures "short" functions: measurement of certain functions every 125 ms, ideal for analysing sound events that are particularly short in duration, recognition of sources, transient signal detection, etc.

One of the most notable applications of the SC420 is the measurement of noise levels belonging to noisy activities, urban and road traffic, machinery such as compressors, pumps, etc. Other important applications are the exposure noise measurement for workers and the measurement of acoustic parameters for the assessment of environmental pollution levels, including impulsiveness and low frequency indices, etc.

13.2.1 Sound level meter mode functions

As a sound level meter , the SC420 measures in the complete dynamic range (one single scale) and, simultaneously, all the functions indicated below:

TIMEBASE	FUNCTIONS
t	L_{Xt} , L_{XE} , L_{Xpeak} , L_{XIt} , $(L_{XIt}-L_{Xt})$, $(L_{Ct}-L_{At})$, L_{nt}
Measurement time	L_{XFmax} , L_{XSmax} , L_{XImax} , L_{XFmin} , L_{XSmin} , L_{XImin} L_{AF5t} , $L_{AF5t}-L_{At}$
T	L_{XT} , L_{XIT} , $(L_{XIT}-L_{XT})$, $(L_{CT}-L_{AT})$, L_{nT}
Programmed integration time	L_{XTmax} , L_{XTmin} L_{AF5T} , $L_{AF5T}-L_{AT}$
1 s	L_{XF} , L_{XS} , L_{XI} , L_{X1s}^* , $L_{Xpeak1s}^*$, $L_{XFmax1s}^*$, $L_{XSmax1s}^*$, $L_{XImax1s}^*$, $L_{XFmin1s}^*$, $L_{XSmin1s}^*$, $L_{XImin1s}^*$
125 ms	$L_{XF125ms}^*$, $L_{XS125ms}^*$, $L_{XI125ms}^*$, L_{X125ms}^* , $L_{Xpeak125ms}^*$

X: indicates the frequency weighting A, C and Z. All functions are measured simultaneously with the three frequency weightings.

n: 1%, 5%, 10%, 50%, 90%, 95% and 99%

*: These functions are measured by the SC420 but are not displayed on screen. The results of these functions can be obtained by making a recording and then downloading it to a PC with **CESVA Lab** (see 17.2)

Percentiles are calculated through the L_{AF} function sampled every 125 ms and class of 0.1 dB.

For the name and definition of each of the functions measured, please see chapter 23.







13.2.2 Sound level meter mode prior adjustments



Configure the three acoustic functions (F1, F2 and F3) displayed on the preference screen, as well as the integration time (T) (see 15.3.1).

13.2.3 Sound level meter mode screens

The sound level meter mode of the SC420 has the following screens:

- Preference
- Numeric
- Time history graphic
- Statistical
- Advanced

The different screens let you view the functions measured (all are measured at the same time). To change screen, you do not need to stop the measurement. All the screens are available for any sound level meter status:      .

In the  **Lxx** and  **SLM** menus, the F1, F2 and F3 functions and the integration time (T) can be configured (see 15.3.1).

PREFERENCE SCREEN:

Shows, on the same screen, the F1, F2 and F3 functions defined in the menu.

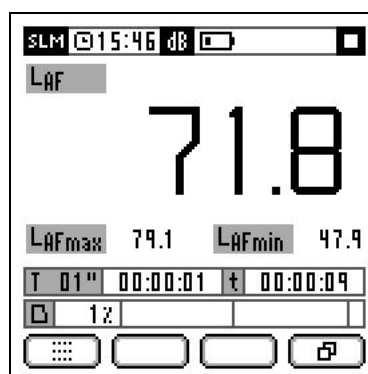

Pressing  takes you to the numeric screen.

NUMERIC SCREEN:

Displays all the functions measured in numeric form.

Pressing **L_{XX}** changes the function frequency weighting.

Pressing **L_{XX}** changes the functions displayed, as below:

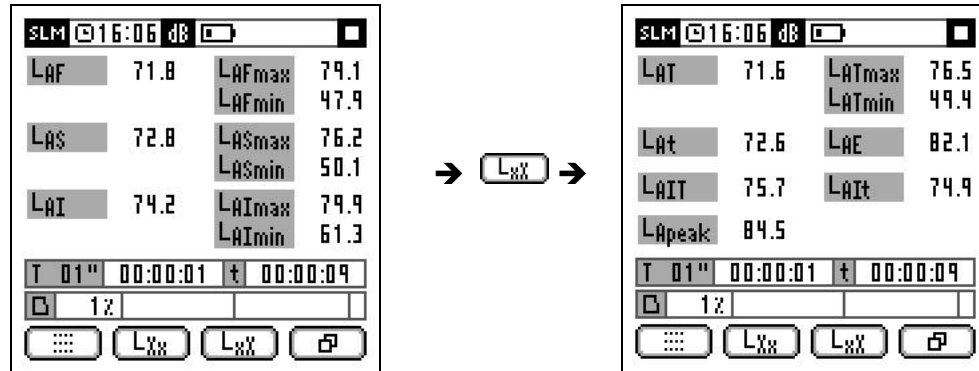

Pressing **☐** takes you to the time history graphic screen.

TIME HISTORY GRAPHIC SCREEN:

Shows the time history and the value of the F1, F2 and F3 functions. Provides a graphic representation of the last 60 values measured.

Pressing **L_{XX}** changes the time history graphic displayed (between F1, F2 and F3).

Pressing **∅+** activates an automatic zoom of the vertical axis [dB] (see 14.1

Pressing **∅-** takes you back to the normal display (without zoom).

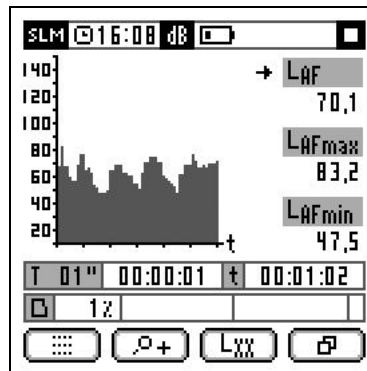

Pressing **☐** takes you to the statistical screen.

STATISTICAL SCREEN:

Numerically displays the percentile values with integration time (T) and integration time corresponding to the measurement time (t) (at the end of the measurement).

Pressing **T** displays the percentiles corresponding to the integration time (T).

Pressing **t** displays the percentiles corresponding to the measurement time (t).

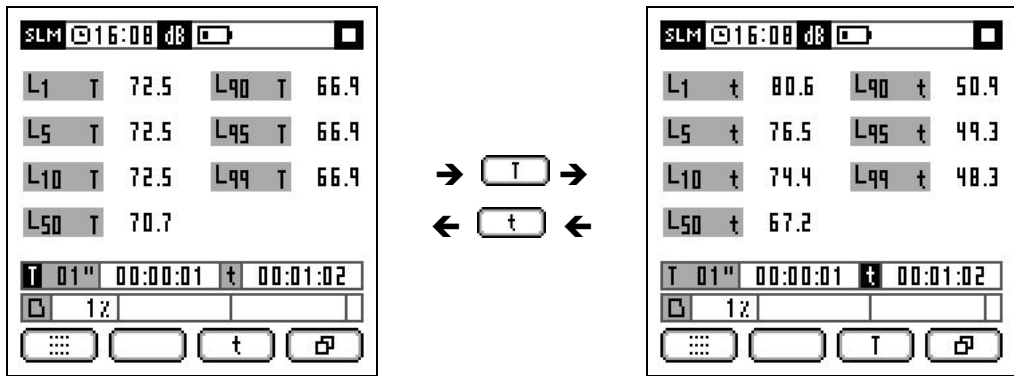



Pressing  takes you to the advanced screen.

ADVANCED SCREEN:

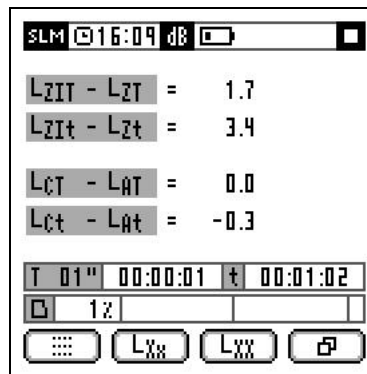
Displays special acoustic functions: impulsiveness indicators, indicators of low-frequency spectral content and functions specific to local, national and international standards.



Pressing  changes the function frequency weighting.

Pressing  changes the functions displayed, as below:

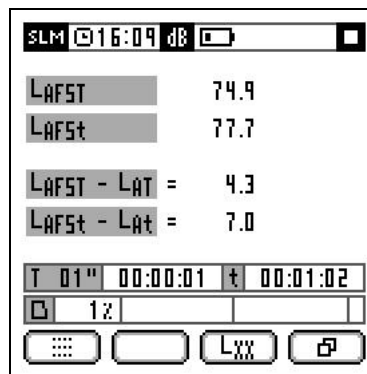

Pressing  takes you to the preference screen.

13.3 1/1 spectrum analyser mode (OPTIONAL)

NOTE: This is an optional mode that can be purchased when you buy the SC420 or later on. See chapter 22.

The 1/1 spectrum analyser is ideal for real-time spectral measurements of the equivalent continuous sound pressure level, octave bands centred on frequencies of 16, 31.5, 63, 125, 250, 500, 1000, 2000, 4000, 8000 and 16000 Hz (without frequency weighting), and simultaneously with global values, equivalent level and peak level, with the frequency weightings (A, C and Z). The SC420 measures these functions for measurement time (t), the consecutive integration time (T) and every 125 ms ("short" functions). It also measures both global and spectral percentiles. The SC420 has a room background noise evaluation screen: NC (Noise Criterion) and NR (Noise Reduction) curves.

Major applications include insulation measurement, frequency analysis of industrial, environmental and workplace noise, and analysis of noise generated by air-conditioning systems and room background noise.

13.3.1 1/1 spectrum analyser mode functions

The SC420, as a **1/1** octave band spectrum analyser, measures in the complete dynamic range (one single scale) and, simultaneously, all the functions indicated below:

TIME BASIS	FUNCTIONS
t: Measurement time	L _{Xt} , L _{Xpeakt} , L _{Ant} L _{ft} , L _{fnT} Evaluation of the NC (63 Hz – 8 kHz) and NR (31,5 Hz – 8 kHz) curves
T: Programmed integration time	L _{XT} , L _{XpeakT} , L _{AnT} L _{fT} , L _{fnT} Evaluation of the NC (63 Hz – 8 kHz) and NR (31,5 Hz – 8 kHz) curves
125 ms	L _{X125ms} *, L _{Xpeak125ms} * L _{f125ms} *

X: indicates the frequency weighting A, C and Z. All functions are measured simultaneously with the three frequency weightings.

n: 1%, 5%, 10%, 50%, 90%, 95% and 99%

f: indicates the octave band filter with central frequency of 16, 31.5, 63, 125, 250, 500, 1000 (1k), 2000 (2k), 4000 (4k), 8000 (8k) and 16000 (16k) Hz. All functions are measured simultaneously with all octave band filters and without frequency weighting.

*: These functions are measured by the SC420 but are not displayed on screen. The results of these functions can be obtained by making a recording and then downloading it to a PC with **CESVA Lab** (see 17.2).

Percentiles are calculated through the L_{A125ms} and L_{r125ms} functions with class of 0.5 dB.

For the name and definition of each of the functions measured, please see chapter 23.





13.3.2 1/1 spectrum analyser mode prior adjustments



Configure the integration time (T) used in the evaluation of spectral and global levels (see 15.3.1).

13.3.3 1/1 spectrum analyser mode screens

The 1/1 octave band spectrum analyser mode of the SC420 has the following screens:

- Graphic
- Numeric
- Statistical
- Time history graphic
- Curves



The different screens let you view the functions measured (all are measured at the same time). To change screen, you do not need to stop the measurement. All the screens are available for any sound level meter status:     .



In the  and  menus, you can configure the integration time (T) (see 15.3.1).



GRAPHIC SCREEN

Displays the real-time spectral graph of the octave band equivalent levels from 16 Hz – 16 kHz (without frequency weighting) for the consecutive integration time (T) and for the measurement time (t).

It also displays the numerical value of the global equivalent level with the frequency weightings A, C and Z and that corresponding to the octave band selected in the graph (vertical cursor) for T and t.

Pressing  displays the values of the functions corresponding to the integration time (T). Pressing  displays the values corresponding to the measurement time (t).

Pressing  activates an automatic zoom of the vertical axis [dB] (see 14.1). Pressing  takes you back to the normal display (without zoom).

To change the band selected, use the  and  selector keys. If you want to go more quickly, hold down the selector key being used.

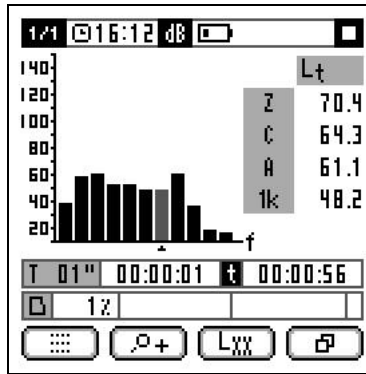

Pressing takes you to the numeric screen.

NUMERIC SCREEN:

Displays the functions measured in numeric form.

Pressing changes the functions displayed, as below:

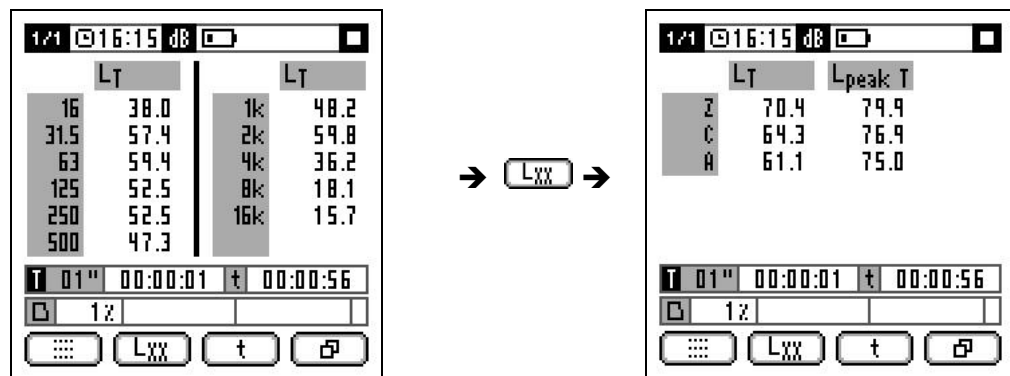

Pressing displays the values of the functions corresponding to the integration time (T). Pressing displays the values corresponding to the measurement time (t).

Pressing takes you to the statistical screen.

STATISTICAL SCREEN:

Numerically displays the percentile values with integration time (T) and integration time corresponding to the measurement time (t) (at the end of the measurement).

Pressing displays the percentiles corresponding to the integration time (T). Pressing displays the percentiles corresponding to the measurement time (t).

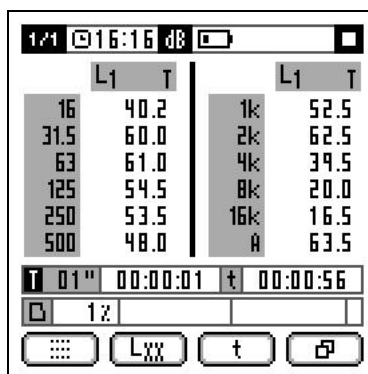

Pressing changes the percentile displayed. The available percentiles are L₁, L₅, L₁₀, L₅₀, L₉₀, L₉₅ and L₉₉.



Pressing  takes you to the time history graphic screen.

TIME HISTORY GRAPHIC SCREEN:

Displays the time history of the LAT function: equivalent level with frequency weighting A and integration time (T). Provides a graphic representation of the last 60 values measured. It also displays the numerical value of the L_{AT} and L_{At} functions.

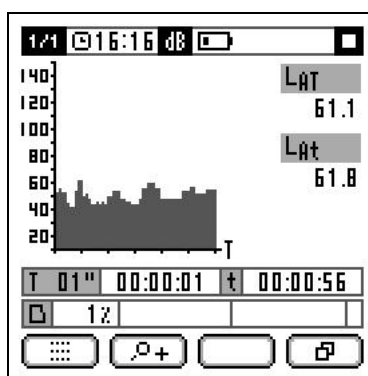

Pressing  activates an automatic zoom of the vertical axis [dB] (see 14.1). Pressing  takes you back to the normal display (without zoom).



Pressing  takes you to the curves screen.

CURVES SCREEN:

Evaluates the spectrum measured according to the NC (Noise Criterion) and NR (Noise Reduction) curves. Displays the numerical value of the curve that does not exceed the spectrum measured (bottom right of the work area). That is, the value of the curve that defines this spectrum and the value of the curve that has not been exceeded in each octave band. This information serves to ascertain which octave band fixes the value of the curve of the total spectrum. That is, at least one spectral value must be equal to the value of the curve that defines the total spectrum.

Pressing  evaluates the spectrum according to the NC (Noise Criterion) curves. Pressing  evaluates according to the NR (Noise Reduction) curves, as below:

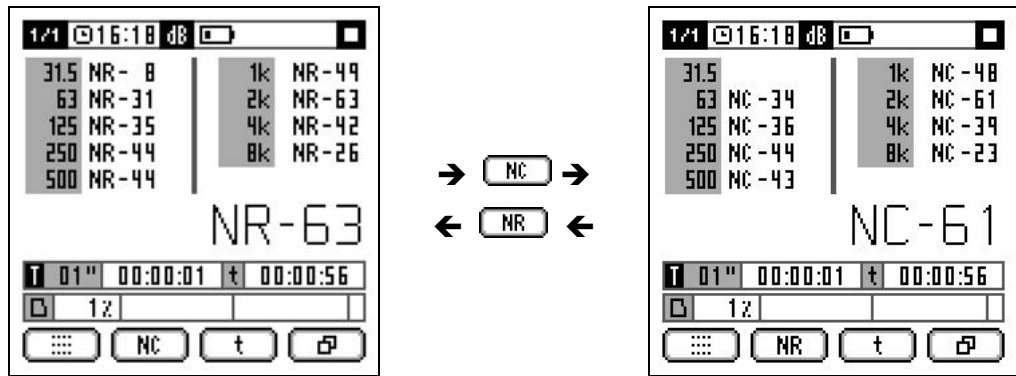

Pressing **T** displays the values of the functions corresponding to the integration time (T). Pressing **t** displays the values corresponding to the measurement time (t).

Pressing **□** takes you to the graphic screen.

13.4 1/3 spectrum analyser mode (OPTIONAL)

NOTE: This is an optional mode that can be purchased when you buy the SC420 or later on. See chapter 22.

The 1/3 spectrum analyser mode has been designed for measuring spectral content with third octave resolution. The SC420 performs a frequency analysis of the equivalent continuous sound pressure level in third octave bands from 10 Hz to 20 kHz (without frequency weighting). This analysis is carried out in real time for all bands and throughout the entire dynamic range of measurement (without scale changes), measuring the equivalent level for the measurement time (t), the consecutive integration time (T) and every 125 ms ("short" functions). At the same time as the spectrum, the SC420 measures the global equivalent level with frequency weighting A, C and Z, together with other sound level meter functions.

The most important applications offered by this mode are: measurement of acoustic insulation in third octave bands, evaluation of environmental noise including corrections for the presence of tonal and impulsive components and low-frequency content, the detection and identification of noise sources, etc.

13.4.1 Spectrum analyser mode 1/3 functions

The SC420, as a **1/3** third octave band spectrum analyser, measures in the complete dynamic range (one single scale) and, simultaneously, all the functions indicated below:

TIMEBASE	FUNCTIONS
t: Measurement time	L _{Xt} , L _{AIt} , L _{AFmaxt} , L _{ASmaxt} , L _{Almaxt} , (L _{AIt} -L _{At}), (L _{AFmaxt} -L _{At}), (L _{Almaxt} -L _{AFmaxt}), (L _{Almaxt} -L _{ASmaxt}), (L _{Ct} -L _{At}), L _{Ant} L _{ft}
T: Programmed integration time	L _{Xt} , L _{AIt} , L _{AFmaxT} , L _{ASmaxT} , L _{AlmaxT} , (L _{AIt} -L _{AT}), (L _{AFmaxT} -L _{AT}), (L _{AlmaxT} -L _{AFmaxT}), (L _{AlmaxT} -L _{ASmaxT}), (L _{CT} -L _{AT}), L _{Ant} L _{fT}
125 ms	L _{X125ms} [*] , L _{A125ms} [*] , L _{AFmax125ms} [*] , L _{ASmax125ms} [*] , L _{Almax125ms} [*] L _{f125ms} [*]

X: indicates the frequency weighting A, C and Z. All functions are measured simultaneously with the three frequency weightings.

n: 1%, 5%, 10%, 50%, 90%, 95% and 99%

f: indicates the third octave band filter with central frequencies of 10, 12.5, 16, 20, 25, 31.5, 40, 50, 63, 80, 100, 125, 160, 200, 250, 315, 400, 500, 630, 800, 1000 (1k), 1250 (1.25k), 1600 (1.6k), 2000 (2k), 2500 (2.5k), 3150 (3.15k), 4000 (4k), 5000 (5k), 6300 (6.3k), 8000 (8k), 10000 (10k), 12500 (12.5k), 16000 (16k) and 20000 (20k) Hz. All functions are measured simultaneously with all third octave band filters and without frequency weighting.

*****: These functions are measured by the SC420 but are not displayed on screen. The results of these functions can be obtained by making a recording and then downloading it to a PC with **CESVA Memory Download** (see 17.2)

Percentiles are calculated through the L_{A125ms} functions with class of 0.5 dB.

For the name and definition of each of the functions measured, please see chapter 23.

13.4.2 1/3 spectrum analyser mode prior adjustments



Configure the integration time (T) used in the evaluation of spectral and global levels (see 15.3.1).

13.4.3 1/3 spectrum analyser mode screens

The 1/3 octave band spectrum analyser mode of the SC420 has the following screens:

- Graphic
- Numeric
- Time history graphic
- Advanced
- Statistical



The different screens let you view the functions measured (all are measured at the same time). To change screen, you do not need to stop the measurement. All the screens are available for any sound level meter status: .



In the  and  menus you can configure the integration time (T) (see 15.3.1).



GRAPHIC SCREEN

Displays the real-time spectral graph of the third octave band equivalent levels from 10 Hz – 20 kHz (without frequency weighting) for the consecutive integration time (T) and for the measurement time (t).

It also displays the numerical value of the global equivalent level with the frequency weightings A, C and Z and that corresponding to the third octave band selected in the graph (vertical cursor) for T and t.

Pressing  displays the values of the functions corresponding to the integration time (T). Pressing  displays the values corresponding to the measurement time (t).

Pressing  activates an automatic zoom of the vertical axis [dB] (see 14.1). Pressing  takes you back to the normal display (without zoom).

To change the third octave band selected, use the  and  selector keys. If you want to go more quickly, hold down the selector key being used.

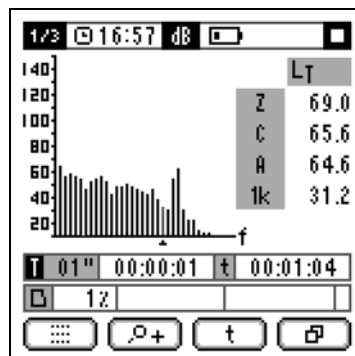

Pressing  takes you to the numeric screen.

NUMERIC SCREEN:

Displays the functions measured in numeric form.

Pressing  changes the functions displayed, as below:

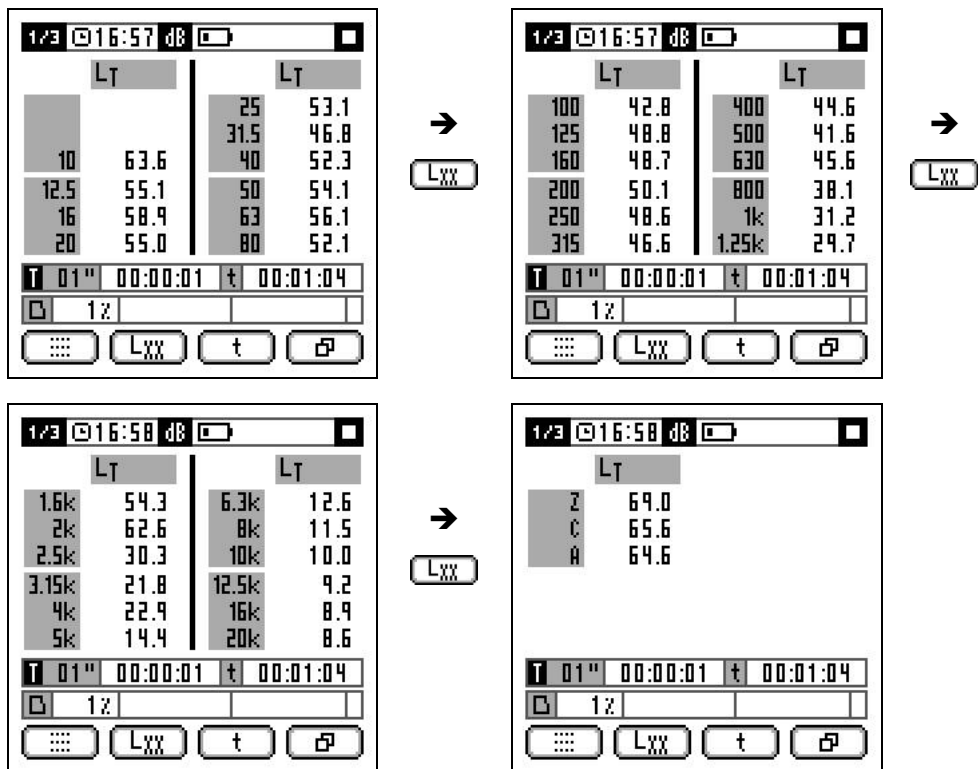

Pressing **T** displays the values of the functions corresponding to the integration time (T). Pressing **t** displays the values corresponding to the measurement time (t).

Pressing **☐** takes you to the time history graphic screen.

TIME HISTORY GRAPHIC SCREEN:

Displays the time history of the L_{AT} function: equivalent level with frequency weighting A and integration time (T). Provides a graphic representation of the last 60 values measured. It also displays the numerical value of the L_{AT} and L_{At} functions.

Pressing **∞+** activates an automatic zoom of the vertical axis [dB] (see 14.1). Pressing **∞-** takes you back to the normal display (without zoom).

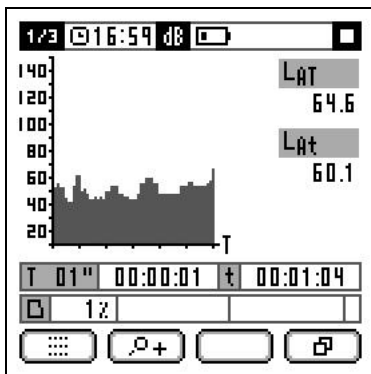

Pressing **☐** takes you to the advanced screen.

ADVANCED SCREEN:

Displays special acoustic functions: impulsiveness indicators, indicators of low-frequency spectral content and functions specific to local, national and international standards.

Pressing **Lxx** changes the functions displayed.

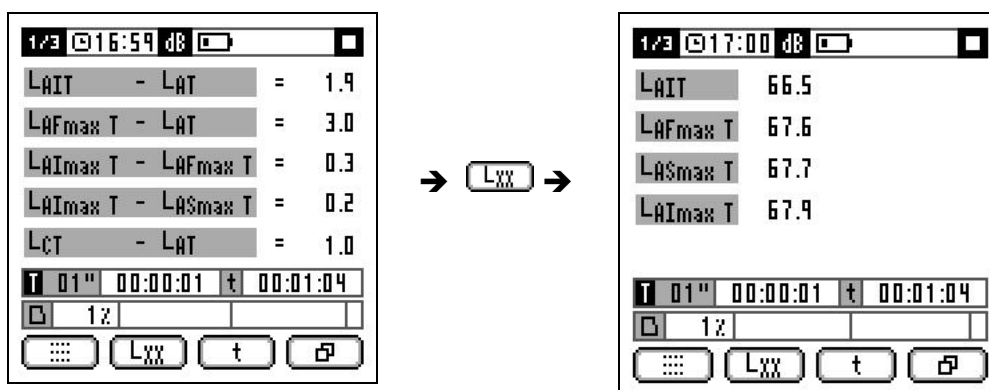

Pressing **T** displays the values of the functions corresponding to the integration time (T). Pressing **t** displays the values corresponding to the measurement time (t).

Pressing **□** takes you to the statistical screen.

STATISTICAL SCREEN:

Numerically displays the global percentile values with frequency weighting A, with integration time (T) and integration time corresponding to the measurement time (t) (at the end of the measurement).

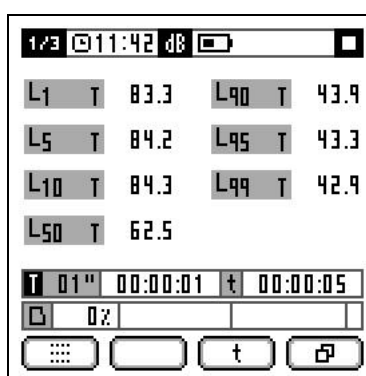

Pressing **T** displays the percentiles corresponding to the integration time (T). Pressing **t** displays the percentiles corresponding to the measurement time (t).



Pressing **□** takes you to the graphic screen.

13.5 Octave (1/1) and third octave (1/3) band reverberation time (interrupted noise method) modes (OPTIONAL)

NOTE: These modes are optional and can be purchased at the same time as the SC420 or later on. See chapter 22.



The octave band reverberation time (interrupted noise method) mode and the third octave band reverberation time (interrupted noise method) mode behave similarly; the  mode measures the reverberation time for octave bands from 63 Hz to 8 kHz and the  mode measures it for third octave bands from 50 Hz to 10 kHz. The interrupted noise consists of obtaining the sound pressure level decay as a function of time inside the room that is being studied. This decay is obtained exciting the room with random noise of broadband or of limited bandwidth and recording the decay level of the sound pressure when the noise emission is cut abruptly. The reverberation times T_{20} and T_{30} are obtained automatically by evaluating the decay curve, using a linear regression analysis by the method of least square approximation.

To take this measurement, you will need an omni-directional pressure source (FP122) that emits a broadband noise (pink or white noise).



With these modes, the SC420 simultaneously measures the value of T_{20} , T_{30} and the decay curves, together with parameters for the evaluation of quality (C, ξ and B·T).

The applications of these modes include the measurement of reverberation time in rooms, the measurement of the absorption coefficients in reverberation rooms, and the measurement of insulation in buildings and of building elements.

13.5.1 Octave (1/1) and third octave (1/3) band reverberation time (interrupted noise method) mode functions

The SC420, in the  octave and  third octave band reverberation time (interrupted noise method) modes, measures the functions indicated below in the complete dynamic range (one single scale):

MODE	FUNCTIONS	FREQUENCIES
1/1 octave band reverberation time mode (interrupted noise method)	T_{20} , T_{30} , L_N , Δ , C, ξ_{20} , B· T_{20} , ξ_{30} , B· T_{30} and the decay curve	For octave band filters with central frequencies of 63, 125, 250, 500, 1000 (1k), 2000 (2k), 4000 (4k), 8000 (8k) Hz
One-third (1/3) octave band reverberation time mode (interrupted noise method)	T_{20} , T_{30} , L_N , Δ , C, ξ_{20} , B· T_{20} , ξ_{30} , B· T_{30} and the decay curve	For third octave band filters with central frequencies of 50, 63, 80, 100, 125, 160, 200, 250, 315, 400, 500, 630, 800, 1000 (1k), 1250 (1.25k), 1600 (1.6k), 2000 (2k), 2500 (2.5k), 3150 (3.15k), 4000 (4k), 5000 (5k), 6300 (6.3k), 8000 (8k), 10000 (10k) Hz.

All functions are measured with all octave band ( mode) and third octave band ( mode) filters, and without frequency weighting.



For the name and definition of each of the functions measured, please see chapter 23.

13.5.2 Taking a measurement in octave (1/1) and third octave (1/3) band reverberation time (interrupted noise method) modes

To measure the reverberation time (interrupted noise method), you should follow these three steps:



■ □ □ **STEP 1:** Measuring the background noise (L_N)

Make sure that the sound emission from the pressure source is stopped.

Press  to start measuring the sound pressure level (L_N) corresponding to the background noise. This level will appear on screen (equivalent level of 1 second in dB) for each octave or third octave band (depending on the mode:  or .

Press  to validate this measurement. These values will stop oscillating and will become fixed.

■ ■ □ **STEP 2:** Measuring the increase in sound pressure level, in relation to background noise (Δ)

The screen will display a new column of values corresponding to the increase in sound pressure level in relation to background noise, Δ (in dB), for each octave or third octave band (depending on the mode:  or ). Alongside these values, two indicators will appear (■ and ▪) warning that the increase in sound pressure level in relation to background noise, for the calculation of the T_{20} and T_{30} in the bands of interest, is not enough. The value of Δ must be at least 35 dB and 45 dB to calculate T_{20} and T_{30} respectively.

- Indicates that the value of Δ is not enough to calculate T_{20} and T_{30} .
- Indicates that the value of Δ is not enough to calculate T_{30} .



Gradually increase the level of the sound pressure source until the indicators ■ and ▪ disappears. Once the source is emitting the necessary sound pressure level, wait a few seconds to allow the acoustic field to reach a stable state.

Press  to validate this level. These values will stop oscillating and will become fixed.

■ ■ ■ **STEP 3:** Measuring the decay curve

From this point, the SC420 will wait for you to interrupt the noise emission.



Stop the noise emission. From this moment, the device measures the decay in the sound pressure level. During this time, it is essential to keep silent so as not to interfere with the measurement.



After a few seconds, after the noise emission ceases, the screen will display the values of T_{20} and T_{30} for each octave or third octave band (depending on the mode:  or ) and the measurement will end automatically.

If next to the value of T_{20} or T_{30} the \square indicator appears, this is an alert to an incident in the quality parameters (C, ξ and/or B·T) as the decay curve from which they are calculated is far from regular line or is influenced by the filters (see the Quality Numeric Screen in subsection 13.5.3).

For the device to display the T_{20} and T_{30} results on screen, these must be at least 0.12 seconds, in addition to complying with the minimum level of Δ (35 dB and 45 dB). If these conditions are not fulfilled, the screen will display - - -.

During the measurement, the following information will appear on the screen:



- INDICATOR AREA: ongoing measurement indicator . The units of the functions that appear in the work area will also be displayed (only for the Graphic Screens).
- WORK AREA: the functions measured and indicators (if applicable).
The functions calculated do not appear until the measurement has ended () together with the indicators, if applicable.

Once the measurement has started, it can be interrupted by pressing . The measurement status indicator will change from  to .



13.5.3 Screens in the octave (1/1) and third octave (1/3) band reverberation time (interrupted noise method) modes



The octave and third octave band reverberation time (interrupted noise method) modes of the SC420 have the following screens:

- Numeric
- Graphic Noise Level
- Graphic Reverberation Time
- Numeric Quality
- Graphic Decay Curves

The different screens display the functions measured and calculated. While measuring , the device allows you to change from the Numeric Screen to the Graphic Noise Level Screen. Once the measurement is completed  or , all screens are available.

NUMERIC SCREEN:

Displays the values of the background noise (L_N), the increase in noise level in relation to the background noise (Δ) together with its indicators, if applicable (see 13.5.2), and the T_{30} and T_{20} octave or third octave band reverberation time, depending on the  or  mode, together with its indicator, if applicable (see 13.5.2).

The  mode displays the values for the 24 bands of third octave bands: to display all of them, use the contextual key .

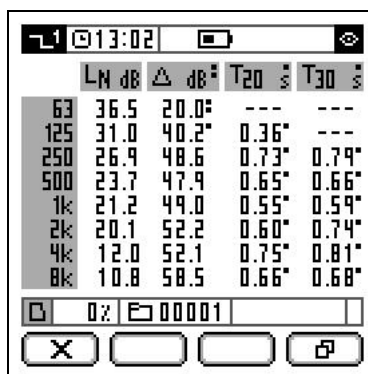

Pressing takes you to the Noise Level Graphic Screen.

NOISE LEVEL (L_N and Δ) GRAPHIC SCREEN:

Displays the spectral graph for the background noise levels (L_N) and for the increase in level in relation to the background noise (Δ) in octave or third octave bands, depending on the or mode. It also displays the numerical value for the background noise level (L_N) and for the increase in noise level in relation to the background noise (Δ), corresponding to the band selected in the graph (vertical cursor) together with its indicators, if applicable (see 13.5.2).

Pressing activates an automatic zoom of the vertical axis [dB] (see 14.1). Pressing takes you back to the normal display (without zoom).

To change the band selected, use the and selector keys.

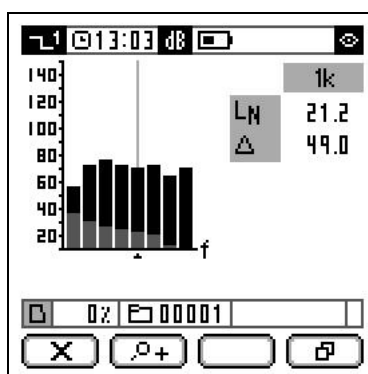

Pressing takes you to the Reverberation Time Graphic Screen.

REVERBERATION TIME (T_{20} and T_{30}) GRAPHIC SCREEN:

Displays the spectral graph for T_{20} and T_{30} in octave or third octave bands, depending on the or mode. It also displays the numeric value for T_{20} and T_{30} , corresponding to the band selected in the graph (vertical cursor) together with its indicator, if applicable (see 13.5.2).

Pressing activates an automatic zoom of the vertical axis [s] (see 14.1). Pressing takes you back to the normal display (without zoom).

To change the band selected, use the and selector keys.

Pressing T_{30} displays the graph corresponding to the T_{30} reverberation time. Pressing T_{20} displays the graph corresponding to the T_{20} reverberation time.

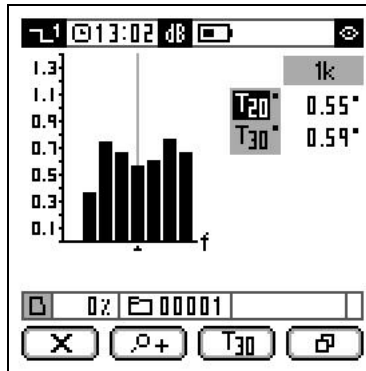

Pressing \square takes you to the Quality Numeric Screen.

QUALITY (C, ξ and B·T) NUMERIC SCREEN:

Displays the values for the curvature parameter (C), the non-linearity parameter (ξ) and the multiplication of the filter bandwidth and the calculated reverberation time (B·T), in octave or third octave bands, depending on the \square^1 or \square^3 mode.

Next to the previous values appears the indicator \blacksquare , warning that the result should be identified as less reliable. This indicator appears:

- If ξ is greater than the value \square currently programmable (see 15.3.1), as the decay curve is considered to be far from a regular line.
- If C is negative or greater than 10%, as the decay curve is considered to be far from a regular line.
- If B·T is less than or equal to 16, as the decay curve is considered to be influenced by the filter.

Where the value of B·T is greater than 999, this is represented as: >999.

Without the value of T_{20} and T_{30} , you cannot obtain the results for C, ξ_{20} , ξ_{30} , B· T_{20} or B· T_{30} , and the screen indicates this by displaying: - - -.

The \square^3 mode displays the values for the 24 bands of third octave bands: to display all of them, use the \square^{\downarrow} contextual key.

Pressing T_{30} displays the values ξ_{30} and B· T_{30} (ξ and B·T calculated for the T_{30} reverberation time). Pressing T_{20} displays the values ξ_{20} and B· T_{20} (ξ and B.T calculated for the T_{20} reverberation time).

T_{20}	C	%	ξ_{20}	ξ_{20} %	B· T_{20}
63	---	---	---	---	---
125	---	---	382.4*	---	10.4*
250	8.2	---	284.6*	---	42.2
500	1.5	---	115.3*	---	74.9
1k	7.3	---	92.9*	---	126.5
2k	23.3*	---	55.4*	---	275.4
4k	8.0	---	39.6*	---	686.7
8k	3.0	---	44.1*	---	>999.9



Pressing \square takes you to the Decay Curves Graphic Screen.



DECAY CURVES GRAPHIC SCREEN:

The graph shows the time history of the decay curve, corresponding to the band selected.

It also numerically displays the value for the background noise level (L_N), the value for the increase in level in relation to the background noise (Δ) and the values for the T_{20} and T_{30} reverberation times together with their indicators, if applicable (see 13.5.2), corresponding to the band selected.

The  mode displays the values for the 24 bands of third octave bands.

Pressing  activates an automatic zoom of the vertical axis [dB] (see 14.1). Pressing  takes you back to the normal display (without zoom).

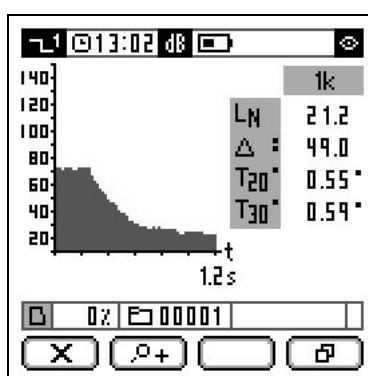

To change the band selected, use the  and  selector keys.



Pressing  takes you to the Numeric Screen.

13.6 Octave (1/1) and third octave (1/3) band reverberation time (integrated impulse response method) modes (OPTIONAL)

NOTE: These modes are optional and can be purchased at the same time as the SC420 or later on. See chapter 22.

The octave band reverberation time (integrated impulse response method) mode and the third octave band reverberation time (integrated impulse response method) mode behave similarly; the  mode measures the reverberation time for octave bands from 63 Hz to 8 kHz and the  mode measures it for third octave bands from 50 Hz to 10 kHz. The integrated impulse response method involves obtaining the decay curve for the sound pressure level from the impulse response of the room under study using Schroeder's method.

First of all the response of the room to a Dirac impulse is measured, obtaining the impulse response. Next, the decay curve is obtained by performing the backward integration of the impulse response according to Schroeder's method. The reverberation times T_{20} and T_{30} are obtained automatically by evaluating the

decay curve, using a linear regression analysis by the method of least square approximation.

As, in practice, it is impossible to emit a Dirac delta, you can emit short transient sounds similar enough to take the measurements.

With these modes, the SC420 simultaneously measures the value of T_{20} , T_{30} and the decay curves, together with the parameters for the evaluation of quality (C, ξ and B·T).

The applications of these modes include the measurement of reverberation time in rooms, the measurement of the absorption coefficients in reverberation rooms, and the measurement of insulation in buildings and of building elements.

13.6.1 Octave (1/1) and third octave (1/3) band reverberation time (integrated impulse response method) mode functions

The SC420, in the **[1]** octave and **[3]** third octave reverberation time (integrated impulse response method) modes, measures the functions indicated below in the complete dynamic range (one single scale):

MODE	FUNCTIONS	FREQUENCIES
Reverberation time (integrated impulse response method) in 1/1 octave bands	T_{20} , T_{30} , L_N , Δ , C, ξ_{20} , B· T_{20} , ξ_{30} , B· T_{30} , the impulse response and the decay curve	For octave band filters with central frequencies of 63, 125, 250, 500, 1000 (1k), 2000 (2k), 4000 (4k), 8000 (8k) Hz.
Reverberation time (integrated impulse response method) in one-third (1/3) octave bands	T_{20} , T_{30} , L_N , Δ , C, ξ_{20} , B· T_{20} , ξ_{30} , B· T_{30} , the impulse response and the decay curve	For third octave band filters with central frequencies of 50, 63, 80, 100, 125, 160, 200, 250, 315, 400, 500, 630, 800, 1000 (1k), 1250 (1.25k), 1600 (1.6k), 2000 (2k), 2500 (2.5k), 3150 (3.15k), 4000 (4k), 5000 (5k), 6300 (6.3k), 8000 (8k), 10000 (10k) Hz.

All functions are measured with all octave band (**[1]** mode) and third octave band (**[3]** mode) filters, and without frequency weighting.

For the name and definition of each of the functions measured, please see chapter 23.

13.6.2 Taking a measurement in octave (1/1) and third octave (1/3) band reverberation time (integrated impulse response method) modes

To measure the reverberation time (integrated impulse response method), the three steps below should be followed:

■ □ □ **STEP 1:** Measuring the background noise (L_N)





Press **[>C]** to start measuring the sound pressure level (L_N) corresponding to the background noise. This level will appear on screen (equivalent level of 1 second in dB) for each octave or third octave band (depending on the mode: **[1]** or **[3]**).

Press  to validate this measurement. The values will stop oscillating and will become fixed.

■ ■ □ STEP 2: Generating the impulsive noise

Generate an impulsive noise such as an alarm (or any other non-reverberant source, but that its spectrum is broad enough) to measure the impulse response of the room. From this moment, it is essential to remain silent, so as not to interfere with the measurement.



■ ■ ■ STEP 3: Measuring the decay curve

A few seconds later, after generating the impulsive noise, the screen will display the values corresponding to the increase in sound pressure level, in relation to the background noise Δ (in dB) for each octave or third octave band (depending on the mode:  or ). Alongside these values, two indicators will appear ( and ) warning that the increase in sound pressure level in relation to background noise, for the calculation of the T_{20} and T_{30} in the bands of interest, is not enough. The value of Δ must be at least 35 dB and 45 dB to calculate T_{20} and T_{30} respectively.

■ Indicates that the value of Δ is not enough to calculate T_{20} and T_{30} .

▪ Indicates that the value of Δ is not enough to calculate T_{30} .

If one of these indicators appears in the frequency of interest it is recommended to repeat the measurement.

The screen will also display the values of T_{20} and T_{30} for each octave or third octave band (depending on the mode:  or ) and the measurement will end automatically.

If next to the value of T_{20} or T_{30} the  indicator appears, this is an alert to an incident in the quality parameters (C, ξ and/or B·T) as the decay curve from which they are calculated is far from regular line or is influenced by the filters (see the Quality Numeric Screen in subsection 13.5.3).



For the device to display the T_{20} and T_{30} results on screen, these must be at least 0.12 seconds, in addition to complying with the minimum level of Δ (35 dB and 45 dB). If these conditions are not fulfilled, the screen will display - - -.

During the measurement, the following information will appear on the screen:

- INDICATOR AREA: ongoing measurement indicator . The units of the functions that appear in the work area will also be displayed (only for the graphic screens).

- WORK AREA: the background noise function.



The other functions appear when the measurement ends () together with the indicators, if applicable.

Once the measurement has started, it can be interrupted by pressing . The measurement status indicator will change from  to .



13.6.3 Octave (1/1) and third octave (1/3) band reverberation time (integrated impulse response method) mode screens



The octave and third octave band reverberation time (integrated impulse response method) modes of the SC420 have the following screens:

- Numeric
- Graphic Noise Level
- Graphic Reverberation Time
- Numeric Quality
- Graphic Curve

The different screens display the functions measured and calculated. While measuring , the device allows you to change from the numeric screen to the graphic noise level screen. Once the measurement is completed  or , all screens are available.

NUMERIC SCREEN:

Displays the values of the background noise (L_N), the increase in noise level in relation to the background noise (Δ) together with its indicators, if applicable (see 13.6.2), and the T_{30} and T_{20} octave or third octave band reverberation time, depending on the  or  mode together with its indicator, if applicable (see 13.6.2).

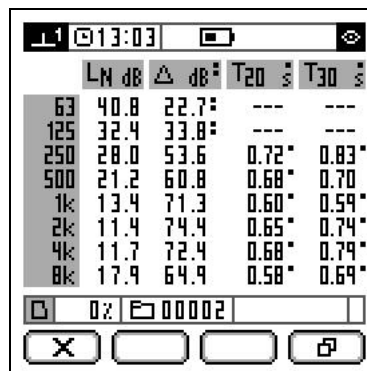

The  mode displays the values for the 24 bands of third octave bands: to display all of them, use the  contextual key.







	L_N dB	Δ dB	T_{20} s	T_{30} s
63	40.8	22.7	---	---
125	32.4	33.8	---	---
250	28.0	53.6	0.72	0.83
500	21.2	60.8	0.68	0.70
1k	13.4	71.3	0.60	0.59
2k	11.4	74.4	0.65	0.74
4k	11.7	72.4	0.68	0.79
8k	17.9	64.9	0.58	0.69

Pressing  takes you to the graphic noise level screen.

NOISE LEVEL GRAPHIC SCREEN (L_N and Δ):

Displays the spectral graph for the background noise levels (L_N) and for the increase in level in relation to the background noise (Δ) in octave or third octave bands, depending on the  or  mode. It also displays the numerical value for the background noise level (L_N) and for the increase in noise level in relation to the background noise (Δ), corresponding to the band selected in the graph (vertical cursor) together with its indicators, if applicable (see 13.6.2).



Pressing  activates an automatic zoom of the vertical axis [dB] (see 14.1). Pressing  takes you back to the normal display (without zoom).

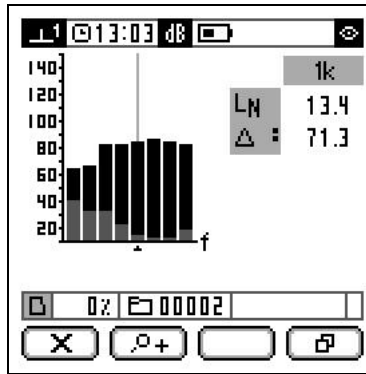

To change the band selected, use the  and  selector keys.







Pressing  takes you to the reverberation time graphic screen.

REVERBERATION TIME (T_{20} and T_{30}) GRAPHIC SCREEN:

Displays the spectral graph for T_{20} and T_{30} in octave or third octave bands, depending on the  or  mode. It also displays the numeric value for T_{20} and T_{30} , corresponding to the band selected in the graph (vertical cursor) together with its indicator, if applicable (see 13.6.2).

Pressing  activates an automatic zoom of the vertical axis [s] (see 14.1). Pressing  takes you back to the normal display (without zoom).

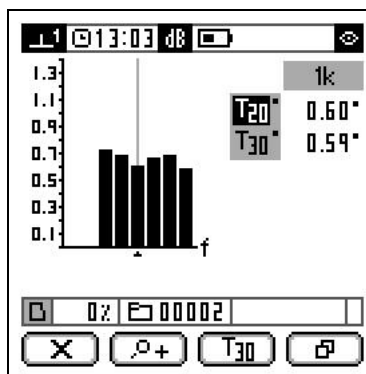

To change the band selected, use the  and  selector keys.

Pressing  displays the graph corresponding to the T_{30} reverberation time. Pressing  displays the graph corresponding to the T_{20} reverberation time.



Pressing  takes you to the quality numeric screen.

QUALITY NUMERIC SCREEN (C, ξ and B·T):

Displays the values for the curvature parameter (C), the non-linearity parameter (ξ) and the multiplication of the filter bandwidth and the calculated reverberation time (B·T), in octave or third octave bands, depending on the  or  mode.

Next to the previous values appears the * indicator, warning that the result should be identified as less reliable. This indicator appears:

- If ξ is greater than 10‰, as the decay curve is considered to be far from a regular line.
- If C is negative or greater than 10%, as the decay curve is considered to be far from a regular line.

- If B·T is less than or equal to 16, as the decay curve is considered to be influenced by the filter.

Where the value of B·T is greater than 999, this is represented as: >999.

The **L3** mode displays the values for the 24 third octave bands: to display all of them, use the **▽** contextual key.

Pressing **T30** displays the values ξ_{30} and B·T₃₀ (ξ and B·T calculated for the T₃₀ reverberation time). Pressing **T20** displays the values ξ_{20} and B·T₂₀ (ξ and B·T calculated for the T₂₀ reverberation time).

f	C	%	ξ_{20}	BT ₂₀
63	---	---	---	---
125	---	---	---	---
250	15.3	20.7	41.6	78.4
500	2.9	11.7	78.4	138.0
1k	-1.7	5.5	138.0	298.3
2k	13.8	8.3	622.6	999.9
4k	16.2	11.3	999.9	999.9
8k	19.0	6.6	999.9	999.9

Pressing **☐** takes you to the graphic curves screen.

GRAPHIC CURVES SCREEN:

Displays the graph of the time history for the impulse response and for the decay curve from which T₂₀ and T₃₀ are calculated, corresponding to the band selected.

It also numerically displays the value for the background noise level (L_N), the value for the increase in level in relation to the background noise (Δ) and the values for the T₂₀ and T₃₀ reverberation times together with their indicators, if applicable (see 13.6.2), corresponding to the band selected.

Pressing **📈** displays the graph corresponding to the time history for the impulse response. Pressing **📉** displays the decay curve obtained through the backward integration method. The decay curve is standardised so that the maximum level is 140 dB.

Pressing **📏+** activates an automatic zoom of the vertical axis [dB] (see 14.1). Pressing **📏-** takes you back to the normal display (without zoom).

To change the band selected, use the **◀** and **▶** selector keys.

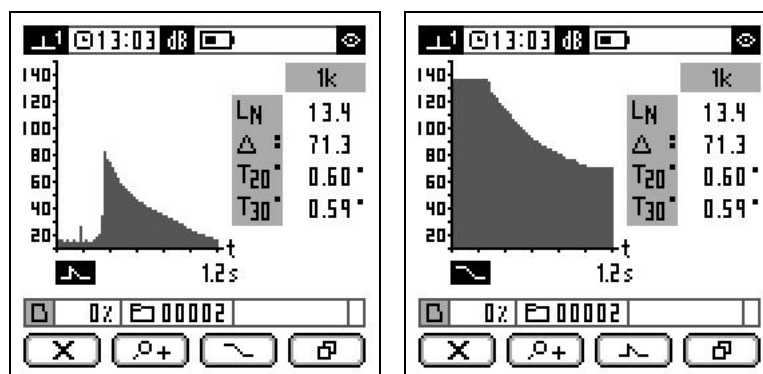

Pressing **☐** takes you to the numeric screen.

13.7 Occupational noise mode (OPTIONAL)

NOTE: This is an optional mode that can be purchased when you buy the SC420 or later on. See chapter 22.

The occupational noise mode of the SC420 is designed for the implementation of ISO 9612:2009 on the determination of exposure to noise at work.

The occupational noise mode simultaneously measures all the parameters required to assess the levels of noise to which workers are exposed with or without hearing protectors (SNR, HML and Octaves). To do this, in addition to measuring the equivalent level with weighting A and C (SNR and HML methods), the SC420 simultaneously performs a real-time frequency analysis by octave bands from 63 Hz to 8 kHz (Octave method).

The device also lets you take measurements that are shorter in duration than the exposition time, as the screen displays the parameters projected to the expected exposure time [programmable time of projection (t_p)].

13.7.1 Occupational noise mode functions

The SC420, as an occupational noise  mode, measures in the complete dynamic range (one single scale) and, simultaneously, all the functions indicated below:

TIME BASIS	FUNCTIONS
t: Measurement time	L_{At} , L_{Ct} , L_{Cpeakt} L_{fxt} $L_{EX,8h}^*$, E^* , $DOSE^*$, $L_{EX,8hp}^*$, E_p^* , $DOSE_p^*$
T: Programmed integration time	L_{AT} , L_{CT} , L_{Cpeakt} L_{fxt}

f: indicates the octave band filter with central frequencies of 63, 125, 250, 500, 1000 (1k), 2000 (2k), 4000 (4k) and 8000 (8k) Hz. All functions are measured simultaneously with all octave band filters and with or without frequency weighting A (see 15.3.1)

X: frequency weighting (A or without weighting)

*: The functions $L_{EX,8h}$, $L_{EX,8hp}$, E , E_p , $DOSE$ and $DOSE_p$ are not saved but they are evaluated according to the L_C and t_p values each time they are recovered.

13.7.2 Occupational noise mode prior adjustments

Configure the criterion level (L_C), the time of projection (t_p), the integration time (T) and, if applicable, the frequency weighting (A) in the spectral analysis in octave bands (A+1/1) (see 15.3.1).

13.7.3 Occupational noise mode screens

The occupational noise mode of the SC420 has the following screens:

- Numeric
- Spectral
- Graphic Time

The different screens let you view the functions measured (all are measured at the same time). To change screen, you do not need to stop the measurement. All the screens are available for any device status:

In the menu, you can configure the criterion level (L_C), the time of projection (t_p) and whether the frequency weighting (A) is included in the spectral analysis in octave bands or not .

NUMERIC SCREEN:

Displays in real time the numerical value for the equivalent daily exposure level ($L_{EX,8h}$), together with the equivalent levels (L_{At} , L_{Ct}) and the peak level (L_{Cpeak}). It also shows the sound exposure (E) and the noise dose (DOSE) in relation to the criterion level (L_C).

Pressing changes the functions displayed, as below:

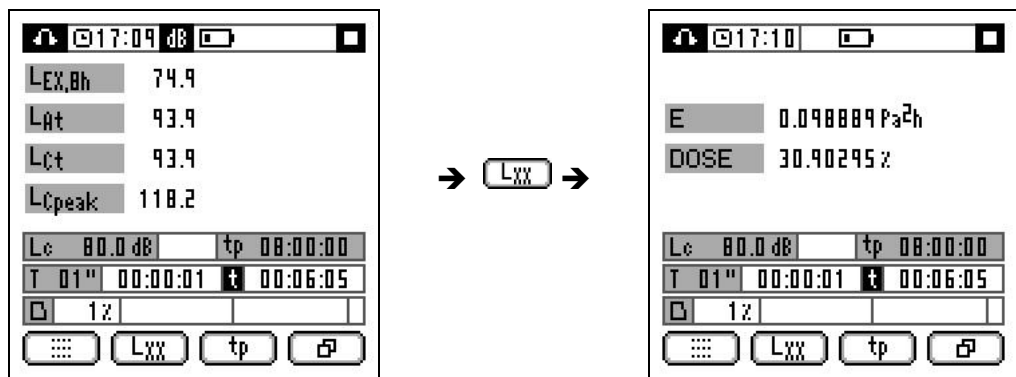

Pressing displays the values of the projected noise exposure functions ($L_{EX,8hp}$, E_p and $DOSE_p$) in relation to the time of projection (t_p). Pressing displays the values ($L_{EX,8ht}$, E and DOSE) corresponding to the measurement time (t).

The projected functions determine the expected noise exposure for an exposure time equal to the programmed time of projection (t_p).

Pressing takes you to the spectral screen.

SPECTRAL SCREEN:

Displays the real-time spectral graph of the octave band equivalent levels from 63 Hz to 8 kHz (with or without frequency weighting A) for the consecutive integration time (T) and for the measurement time (t).

It also displays the numerical value of the global equivalent level with the frequency weightings A and C, that corresponding to the octave band selected in

the graph (vertical cursor) and the peak level with frequency weighting C for T and t.

Pressing \boxed{T} displays the values of the functions corresponding to the integration time (T). Pressing \boxed{t} displays the values corresponding to the measurement time (t).

Pressing $\boxed{dB+}$ activates an automatic zoom of the vertical axis [dB] (see 14.1). Pressing $\boxed{dB-}$ takes you back to the normal display (without zoom).

To change the octave band selected, use the $\boxed{\leftarrow}$ and $\boxed{\rightarrow}$ selector keys.

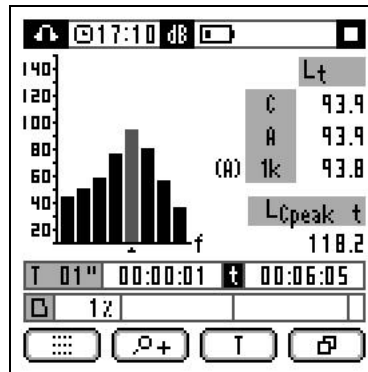

Pressing $\boxed{dB-}$ takes you to the Graphic time history screen.

TIME HISTORY GRAPHIC SCREEN:

Displays the time history of the L_{AT} function: equivalent level with frequency weighting A and integration time (T). It provides a graphic representation of the last 60 values measured. It also displays the numerical value of the L_{AT} and L_{At} functions.

Pressing $\boxed{dB+}$ activates an automatic zoom of the vertical axis [dB] (see 14.1). Pressing $\boxed{dB-}$ takes you back to the normal display (without zoom).

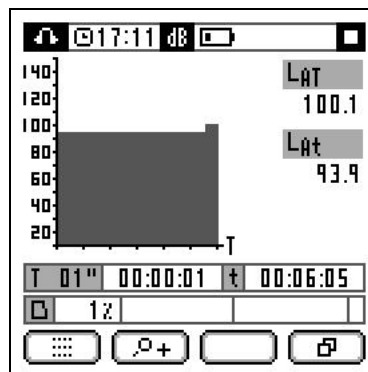

Pressing $\boxed{dB-}$ takes you to the numeric screen.

13.8 FFT frequency analyser mode (OPTIONAL)

NOTE: This is an optional mode that can be purchased when you buy the SC420 or later on. See chapter 22.

The FFT frequency analysis mode (**FFT**) of the SC420 sound level meter performs constant bandwidth frequency analysis from 0 Hz to 20 kHz in real time and in the complete dynamic measurement range (without scale change). The FFT analysis has 10,000 effective lines with a resolution of 2 Hz/line. The SC420 measures the equivalent continuous sound pressure level from 1 to 60 seconds with frequency weighting A and Z for each FFT line.

In this mode, the resolution at high frequencies is greater than in the spectrum obtained in the 1/3 octave with percentage bandwidth mode.

The most important applications offered by this working mode are as follows: detection and evaluation of tonal components when these are between two third octave bands, frequency analysis of transient and continuous signals (in industrial and environmental surroundings), detailed evaluation of tonal components as per ISO 1996-2 and DIN 45681, etc.

13.8.1 Taking an FFT measurement

IMPORTANT: Ensure a microSD memory card is inserted in the slot. You can check this by ensuring the memory card symbol is displayed in the memory area of the screen. If there is no card, it will be impossible to start a recording.

Once in the **FFT** mode (see 13.1), press  to start measuring.

During the measurement, the following information will appear on the screen:

- INDICATOR AREA: ongoing measurement indicator .
- WORK AREA: progress bar indicating the measurement time (limited to one minute).
- TIMING AREA: recording time elapsed.
- MEMORY AREA: memory space used; current register number.



NOTE: The maximum duration of each record is 1 minute. Therefore, if the measurement is not stopped manually () , the device will stop automatically after 1 minute.

Once the measurement has started, it can be stopped by pressing .

After completing the measurement, the sound level meter processes the data measured to obtain the FFT narrow band frequency analysis. This step can take several minutes. During this time, a clock appears in the work area, together with the percentage indicating the progress of this process. Finally, the  status indicator appears.

To save the measurement to memory, please see 16.1.

13.8.2 FFT frequency analysis mode screen

After finishing the measurement, the SC420 presents all the information on a single screen:



FFT GRAPHIC SCREEN:

Displays the graph of the equivalent continuous sound pressure level for each FFT line with frequency weighting A and Z. At the top right of this work area appears the indicator for the frequency weighting displayed.

In the timings area the indicator of the frequency interval displayed appears, together with the numerical value of the frequency and of the equivalent continuous sound pressure level for the FFT line selected by the cursor, and the integration time.

The equivalent continuous sound pressure level for each line corresponds to the energy average of the equivalent continuous sound pressure levels of the frequencies contained in the line.

The memory area displays the used memory space.

Pressing  displays the data with frequency weighting A. Pressing  displays the data with frequency weighting Z.

To change the band selected, use the  and  selector keys. If you want to go more quickly, hold down the selector key being used.

This screen allows you to select the number of lines displayed (1x, 2x, 5x, 10x, 20x, 50x and 100x). Only the display will change, because the resolution of the evaluation will always remain the same.

Frequency interval	Display resolution (Hz/line)	No. of lines displayed
1x	200	100
2x	100	200
5x	40	500
10x	20	1,000
20x	10	2,000
50x	4	5,000
100x	2	10,000

To change the frequency interval displayed, use the  and  keys.

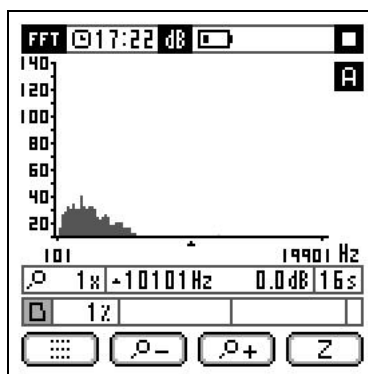

13.9 Audio recording mode (analysis quality) (OPTIONAL)

NOTE: This is an optional mode that can be purchased when you buy the SC420 or later on. See chapter 22.



The audio recording mode (analysis quality) enables you to save the audio signal received by the microphone on the memory card.

This signal is saved without compressing; it is therefore suitable for professional use. As there is no loss of quality, it can provide all the information required to carry out post-processing in much greater detail, if you have the right software.

This mode may be advantageous whatever application you are working in, since it can provide you, after the fact, with much more information on the situation under study.

13.9.1 Making an audio recording (analysis quality)

IMPORTANT: Ensure a microSD memory card is inserted in the slot. You can check this by ensuring the memory card symbol is displayed in the memory area of the screen. If there is no card, it will be impossible to start a recording.

Once in the  mode (see 13.1), press  or  to begin the audio recording process.

During the recording, the following information will appear on the screen:

- INDICATOR AREA: recording in progress indicator .
- WORK AREA: progress bar indicating the measurement time. Limited to 1 minute.
- TIMING AREA: recording time elapsed.
- MEMORY AREA: memory space used, number of the current record and number of the audio file associated with the recording in progress (record number).

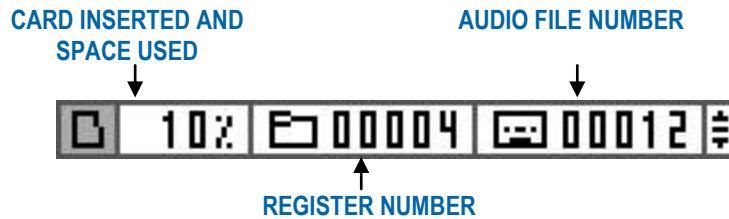

NOTE: The maximum duration of each audio record is 1 minute. Therefore, if the recording is not stopped manually (), the device will stop automatically after 1 minute.

Once the recording has started, it can be stopped by pressing .

After the recording ends, the sound level meter saves the audio file to memory (see 16.2.1). This step can take several minutes. During this time, a clock appears in the work area, together with the percentage indicating the progress of this process. Finally, the indicator area displays the status indicator .

The characteristics of the audio file (analysis quality) are:

- Format: WAV
- Resolution: 24 bits
- Sampling frequency: 48 kHz

Depending on the dynamic range of the recorded signal, the SC420 can apply a constant gain of 36 dB throughout the recording. This is indicated in the file name:

record no.-**036dB** yyyy-mm-dd hh-mm-ss (file **with** gain)

record no.-**000dB** yyyy-mm-dd hh-mm-ss (file **without** gain)

The SC420 includes advanced options to help the user while measuring and to make continuous noise monitoring possible without the user having to be present.

To help the user while measuring, the SC420 incorporates automatic zoom on graphic displays, Backerase, different marks and voice comments recording. For continuous monitoring with or without the user, the SC420 incorporates audio recording and time- and level-controlled automatic start/stop measurement/audio recording automatisms.

14.1 Zoom

The graphic representation of the wide dynamic measurement range of the SC420 does not allow the correct appraisal of very stable noise events on the graphic screens for time evaluation and spectral content.

A sound event with time variations of just a few decibels will appear represented as a virtually constant event. Likewise, a spectrum with small differences in level between bands will be represented practically as a pink noise.

The graphic display screens of the SC420 are equipped with the zoom option, which adapts the scale of the vertical axis to the dynamic range of the interval or spectrum of the sound event represented.

Pressing $\rho+$ activates an automatic zoom of the vertical axis (or abscissas for the FFT mode). At any given moment, the scale of the axis could vary to obtain the best possible display of the range or spectrum represented. It is therefore possible to see variations that would otherwise be invisible.

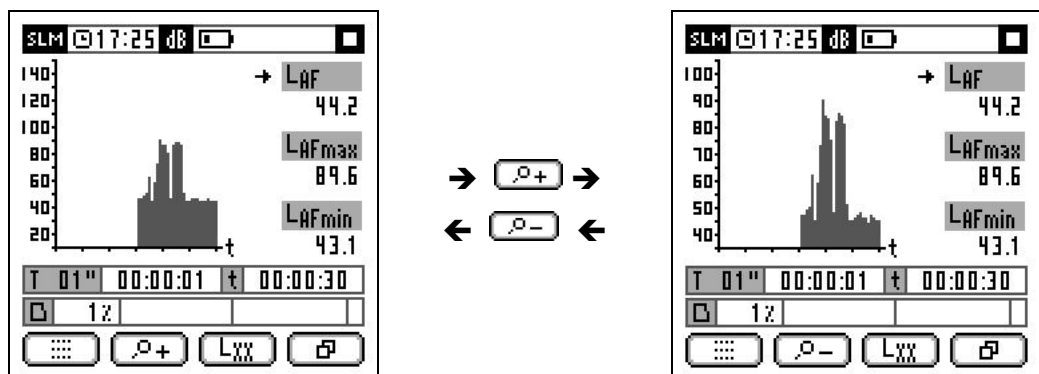

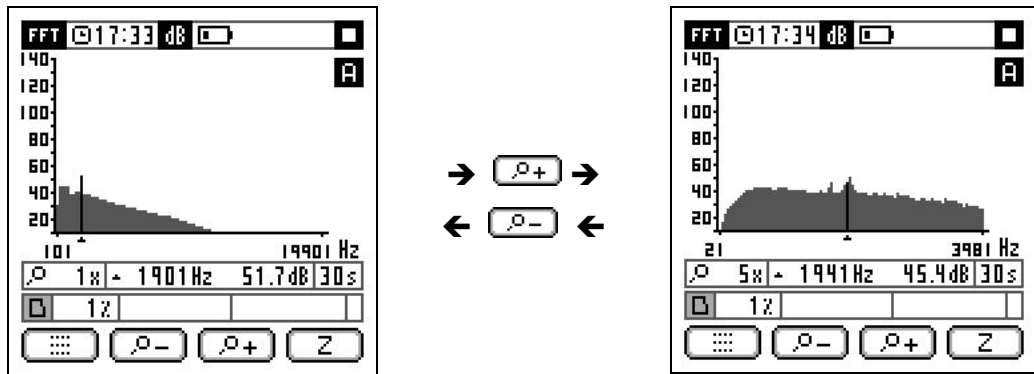

Pressing **P-** takes you back to the normal display (without zoom).

14.2 Backerase

While measuring a sound event, especially while measuring background noise, unexpected sounds can appear that do not correspond to the sound event you want to evaluate, and the sound level meter may end up measuring these. In these situations, you might like to use the Backerase option.

While the measurement is temporarily paused **||**, this option lets you erase the last 10 seconds of the measurement or recording. It is essentially as if you had pressed the **u0** button 10 seconds sooner than you actually did.

To use the Backerase option:

Once you detect the appearance of an unwanted sound event during a measurement or recording and it has affected that process, stop it for a moment by pressing **u0**. The status indicator will change to measurement temporarily paused **||**.

Press **u1** and the last 10 seconds of the measurement or recording will be erased.

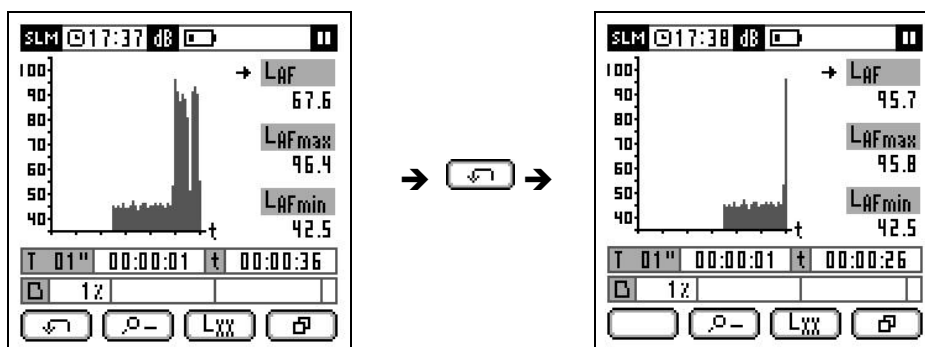

The Backerase option is available on any display screen while measurement or recording is temporarily paused **||**.

The Backerase option is not available for the following modes: time reverberation measurement; FFT frequency analysis; or analysis quality audio recording.

NOTE: The Backerase function can be used once 10 seconds have elapsed since the start of the measurement or recording.

The Backerase function can only be used once during a pause . Once the measurement is resumed, the function may be used again after 10 seconds.







IMPORTANT: The use of the Backerase function may involve loss of information on the percentile functions of any integration period (T).

14.3 Marking

When measuring a sound event, there are often occurrences that you wish to highlight for easier identification afterwards. To this end, the SC420 is equipped with the marking function.

This function is available while making a recording in any mode, except the reverberation time, FFT and audio recording modes.

To mark an event, its start and end will be indicated. The device allows you to use up to three types of mark in the same recording. These are described below:

- **MARK 1:**
To indicate the start of the event, press the  selector key, and the  symbol will appear automatically on the right-hand side of the memory area. To indicate the end, press the same  selector key.
- **MARK 2:**
To indicate the start of the event, press the  selector key, and the  symbol will appear automatically on the right-hand side of the memory area. To indicate the end, press the same  selector key.
- **MARK 3:**
To indicate the start of the event, use the external output (external output at 0), and the  symbol will appear automatically on the right-hand side of the memory area. To indicate the end of the event, use the external output again (external output at 1).

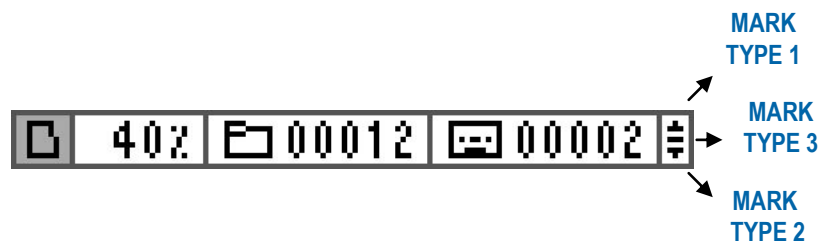

14.4 Voice comments

It is often necessary to make notes, comments and indications regarding the measurements, environment, etc. For example: comments on measuring points, decisions made on site or spontaneous ideas. To meet this need, the SC420 allows users to record voice comments quickly and easily.

This option uses the device's memory to store audio records with the comments made (see 16.3). These can be used to classify measurements, indicate their validity, etc.

To record a voice comments, accede to the main menu (see 12.1):

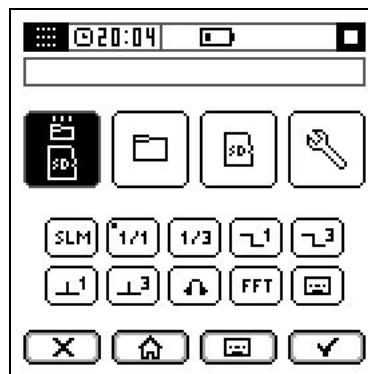

Press  and the audio recording will start automatically.

The maximum duration of each voice comment is 15 seconds. Therefore, if it is not interrupted manually , the device will stop the voice recording automatically after 15 seconds.

After recording, the sound level meter saves the audio file in memory (see 16.3). This step can take several seconds. During this time, a clock appears in the work area, together with the percentage indicating the progress of this process.

The characteristics of the audio files for "voice comments" are:

- Format: WAV
- Resolution: 16 bits
- Sampling frequency: 24 kHz
- Gain: automatic to optimise listening

The file-saving process can take several seconds (30s).

NOTE: You cannot record a voice comment if there is no microSD memory card inserted in the SC420 or if the card is full (see 16.2).

14.5 Audio recording (listening quality)

The SC420 allows you to record audio files at the same time as recording acoustic functions , for recognition and subjective evaluation of sound sources (listening quality).

Having the audio belonging to the sound pressure levels measured provides additional information that facilitates the evaluation of those levels and decision making.

NOTE: It is also possible to record audio fragments with analysis quality for subsequent reanalysis. To do so, use the analysis quality audio recording mode (see 13.9.1).

Audio recording (listening quality) can be carried out either manually or by using configurable automatisms (timers and level triggers). For this last option, please see 14.6.3.

The audio recording option is available during any recording, regardless of the measurement mode.

Pressing  initiates a 15-second audio recording (5 s prerecording, before pressing the key, plus 10 seconds of recording). The memory area displays the number of the audio file associated with the recording in progress (register number).

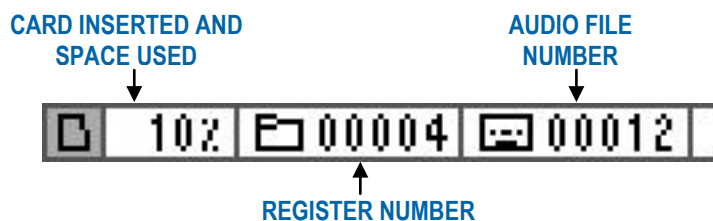



The maximum duration of each audio record is 15 seconds. Therefore, if the recording is not interrupted manually () , the device will stop the audio recording automatically after 10 seconds.

After finishing the audio recording, the sound level meter saves an audio file to memory. The characteristics of the audio files for "listening quality" are:

- Format: WAV
- Resolution: 16 bits
- Sampling frequency: 24 kHz
- Gain: automatic to optimise listening

The process for saving audio files can take several seconds (30s) and does not affect the recording of acoustic functions. During this time, the audio recording key will not be available; it will reappear once the file-saving process has been completed.



NOTE: You can only make audio recording during recording  process. You can never make an audio recording during a measurement , nor you can make an audio recording if there is no microSD memory card inserted in the SC420 or if the card is full (see 16.2).

14.6 Automatic settings: Timers and triggers

The SC420 has a complete system of automatic settings for starting and stopping measurement and audio recording using automatic timers and triggers activated by exceeding the threshold by time intervals. This extends even further the possibilities for using the SC420 as a stand-alone unit for continuous monitoring of noise, without having to be present to carry out a measurement.

14.6.1 Start measurement/recording automatically

This option enables measurements or recordings to be started automatically. In the  settings menu, you can set one of the following types of automatic start:

- Without setting --
- Start set for specific time 
- Start set by waiting time 
- Start set by DEN level dB
- Start set by external digital input Ext.

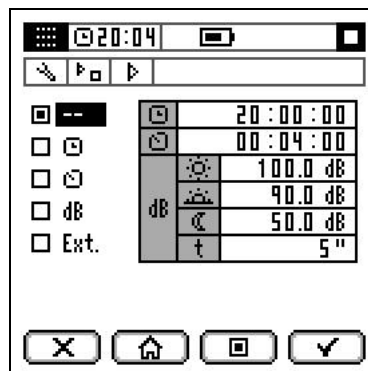

START SET FOR SPECIFIC TIME

The SC420 waits for the clock to reach the programmed time hh:mm  20:00:00 before starting the measurement/recording.

START SET BY WAITING TIME

The SC420 waits for the programmed waiting time to elapse hh:mm:ss  00:04:00 before starting the measurement/recording.

START SET BY DEN LEVEL dB :

The SC420 waits for the sound pressure level ($L_{\text{Aeq1''}}$) to exceed the threshold of the current DEN time interval for more than t seconds before starting the measurement/recording.

dB		100.0 dB
		90.0 dB
		50.0 dB
	t	5''

START SET BY EXTERNAL DIGITAL INPUT **Ext.**:

The SC420 waits for the external digital input to read 0 before starting the measurement/recording.

Once the type of automatic start and its characteristics are set (see 15.3.3), access to the desired measurement mode and start a measurement or a recording by pressing or . Then the or symbol in the indicator area shows that there is an automatic start of measurement or recording programmed, along with one of the following standby screens with the corresponding information.

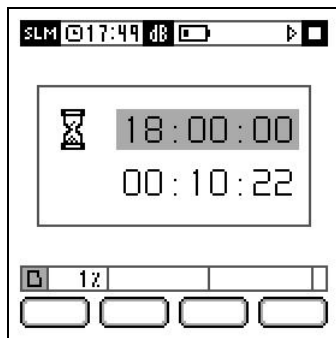

Programmed start time

Time until start

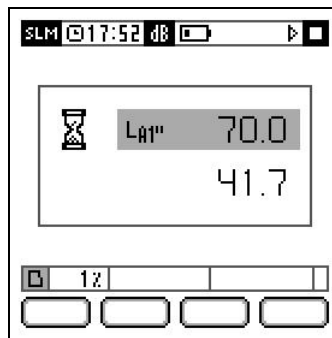

Threshold level for start

Current $L_{\text{Aeq1''}}$ level

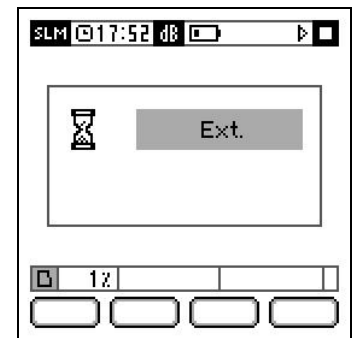

Logical level for start

To exit the standby screen, stop the measurement/recording by pressing .

To configure that start of automatic recording/measurement, please see 15.3.3.

14.6.2 Automatically stop measuring/recording

This option enables a measurement or recording to be stopped automatically. In the settings menu, you can set one of the following types of automatic stop:

- Without setting--
- Stop set for a specific time
- Stop set by waiting time
- Stop set by DEN level dB
- Stop set by external digital input **Ext.**

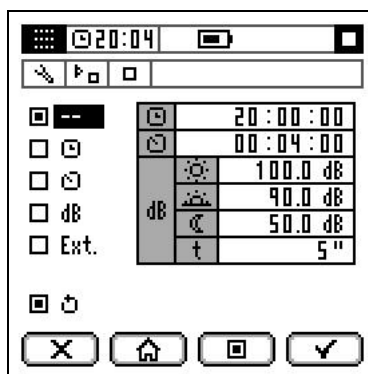

STOP SET FOR A SPECIFIC TIME :



The SC420 waits for the clock to reach the programmed time hh:mm  20:00:00 before stopping the measurement/recording.

STOP SET BY WAITING TIME :

The SC420 waits for the programmed waiting time to elapse hh:mm:ss  00:04:00 before stopping the measurement/recording. The measurement/recording will last for the programmed duration.

STOP SET BY DEN LEVEL dB:

The SC420 waits for the sound pressure level (L_{Aeq1}) to fall below the threshold of the current DEN time interval for more than t seconds before stopping the measurement/recording.



dB		100.0 dB
		90.0 dB
		50.0 dB
	t	5"

STOP SET BY EXTERNAL DIGITAL INPUT Ext.:

The SC420 waits for the external digital input to read 1 before stopping the measurement/recording.

REPEAT OPTION:

If you have set an automatic start and stop measurement and have activated the repeat option , you can create a permanent measuring loop (see 15.3.3).



Once the type of automatic stop and its characteristics are set (see 15.3.3). Access the desired measurement mode, press  or  to start a measurement or recording and wait for it to start (if there is any start programmed). Once it has started, the  symbol will appear in the indicator area to show that the 'stop measurement or recording automatically' setting is programmed.

To configure the 'stop recording/measurement automatically' setting, please see 15.3.3.

14.6.3 Automatic audio recording

This option enables you to make automatic audio recordings. To make an audio recording, whether automatic or manual, there must be a recording in progress (whether automatic or non-automatic).



Audio recordings are always 15 seconds in duration (5 seconds of prerecording and 10 seconds of recording after it starts). After 10 seconds, the audio file is saved (this takes approx. 30 seconds) and then the device waits for a new audio recording while the recording is under way .

In the    settings menu, you can set one of the following types of automatic audio recording:

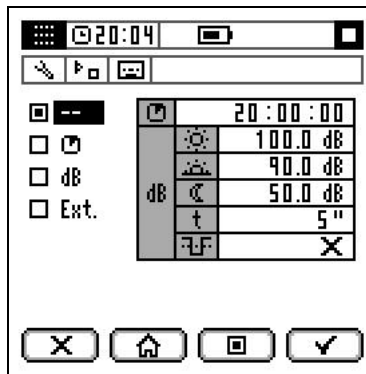
- Without setting --
- Audio recording set by time between recordings 
- Audio recording set by DEN level dB
- Audio recording by external digital input Ext.









AUDIO RECORDING BY TIME BETWEEN RECORDINGS



Firstly, the SC420 starts an audio recording. The SC420 then waits for the programmed waiting time between the start of recordings (hh:mm:ss)  20:00:00 to elapse and subsequently starts a new audio recording. This continues until the end of the recording .

AUDIO RECORDING BY DEN LEVEL dB:

Firstly, the SC420 waits for the sound pressure level (L_{Aeq1}) to exceed the threshold of the current DEN time interval for more than t seconds before starting the audio recording.

		100.0 dB
		90.0 dB
dB		50.0 dB
	t	5"
		X

If the option NEW EVENT is deactivated  X, once the audio recording (5+10 seconds) ends and the file is saved, the SC420 waits for the sound pressure level (L_{Aeq1}) to exceed the threshold of the current DEN time interval for more than t seconds again before making a new audio recording. This continues until the end of the recording .

If the NEW EVENT option is activated  , once the audio recording ends (5+10 seconds) and the file is saved, the SC420 waits for a new event before making a new audio recording. In other words the sound pressure level (L_{Aeq1}) needs to be lower than the threshold of the current DEN time interval for more than t seconds, subsequently exceeding it for more than t seconds. This continues until the end of the recording .

NOTE: With this option, an audio file (15s) will only be recorded at the beginning of each sound event that exceeds the threshold, rather than record consecutively files throughout all events.



While the SC420 is waiting for the conditions required to make an automatic audio recording, the  symbol will appear in the memory area of the screen.









To configure automatic audio recording, see 15.3.3.

14.6.4 DEN intervals

The trigger thresholds for both recording/measurement and audio recording are closely linked to the limits indicated in environmental regulations and laws which typically set them for three evaluating time periods that split the day into: day, evening and night.

The automatic stop and start for measuring/recording and audio recording by dB DEN level settings let you set trigger thresholds for three time intervals: ,  and .

In the    settings menu, you can set the beginning and end of the three time intervals into which the day is divided:

-  DAY
-  EVENING
-  NIGHT

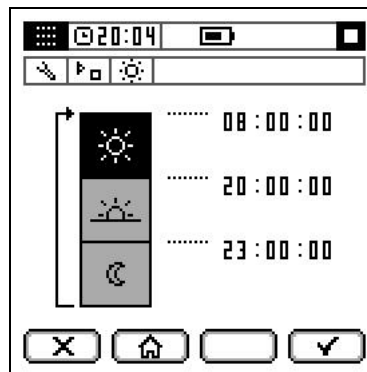

To configure the DEN intervals, please see 15.3.3.

14.6.5 Examples of automatic measurement settings

The following sections explain different settings for automatic stopping/starting of measurement/recording and automatic audio recording designed for a range of everyday situations:



- Measurement of background noise in a home in a rural area
- Assessment of exposure to noise at a factory
- Monitoring the immission of an activity in a home
- Monitoring the emissions produced by public highway cleaning and maintenance machinery
- Continuous monitoring of a port infrastructure
- Monitoring the noise generated by the loading and unloading of a transport fleet

MEASUREMENT OF BACKGROUND NOISE IN A HOME IN A RURAL AREA

SITUATION: Measuring the levels of background noise in a bedroom of a home in a rural area, with expected levels close to 25 dBA. It is necessary to carry out the measurement within the bedroom without the operator or observers being present.

PROGRAMMING:



RESULT: When pressing , the SC420 waits 1 minute and then starts to measure for 6 minutes. This gives the operator time to press , leave the bedroom (together with the observers) and close the door. They wait 6 minutes and re-enter after the measurement is completed.

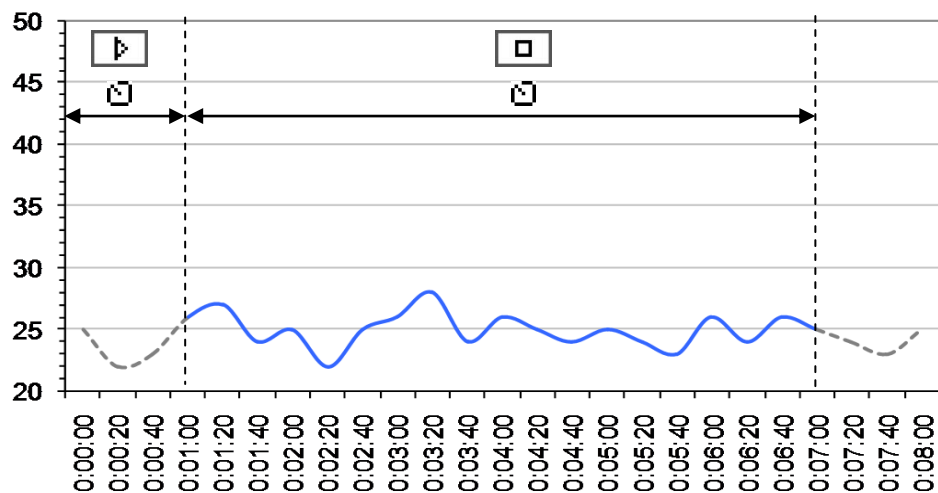



ASSESSMENT OF EXPOSURE TO NOISE AT A FACTORY

SITUATION: Assessment of the exposure to noise of a worker on a 20:00 to 06:00 nightshift. It is possible to precisely measure the exact shift without the operator being present.

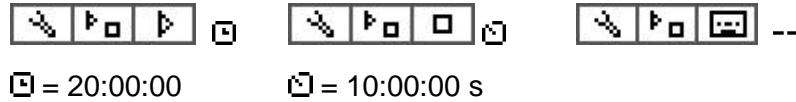
PROGRAMMING:



RESULT: When pressing , the SC420 waits until the clock reaches 20h00m00s and starts to measure for 10 hours. The operator can press  long before 20h00m00s and return the following morning to collect the SC420.

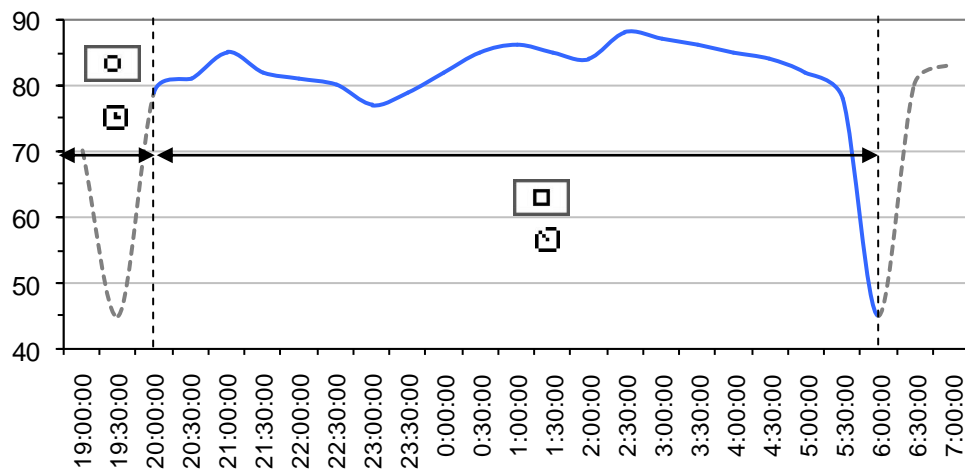



MONITORING THE IMMISSION OF AN ACTIVITY IN A HOME

SITUATION: Monitoring the musical immission of a night club into the interior environment of a dwelling located just above it. The opening hours of the night club are from 00:00 to 05:30. It is necessary to carry out periodic audio recordings to ensure that the noise levels measured during the opening hours belong to the night club.

PROGRAMMING:



RESULT: When pressing , the SC420 waits until 23:30 and then starts recording the noise levels; in parallel, it carries out periodic audio recordings every 30 minutes to subjectively assess the origin of the measured levels. Finally, the SC420 stops the recording at 06:00. Should you wish to carry out the same operation the following day, you would only have to programme the REPEAT option  .

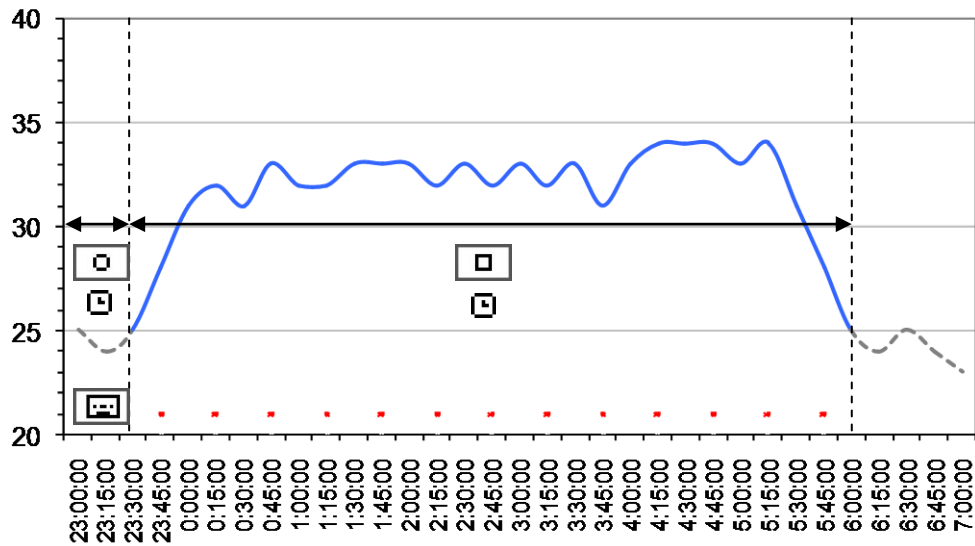

MONITORING THE EMISSIONS PRODUCED BY PUBLIC HIGHWAY CLEANING AND MAINTENANCE MACHINERY

SITUATION: Monitoring the noise generated by the various recycling collection vehicles (for paper, plastic, glass and organic matter) during the night; checking that the 50 dBA immission limit is not exceeded during the night: some vehicles can generate up to 60 dBA. Audio is required to identify the sound events that exceed 60 dBA.

PROGRAMMING:

			dB				dB				dB
	140.0	dB		140.0	dB		140.0	dB		140.0	dB
	140.0	dB		140.0	dB		140.0	dB		140.0	dB
	50.0	dB		50.0	dB		50.0	dB		60.0	dB
	5	s		20	s		5	s		5	s
	08:00:00		18:00:00		22:00:00						

The D and E interval thresholds are programmed to 140 dB in order to prevent triggering any recording during the morning and afternoon.

RESULT: When pressing , the SC420 waits for night-time hours (22:00 to 08:00) to begin before carrying out recordings of the events in excess of 50 dBA for more than 5 seconds. The recording ends when the sound level falls below 50 dB for more than 20 seconds. This ensures that even if the noise generated by the vehicles is intermittent, it is collected in a single recording per vehicle. If the level generated exceeds 60 dBA, audio is recorded to identify the vehicles and

thus be able to correct the defects in these vehicles. A policy will be developed to renew the oldest and noisiest vehicles.

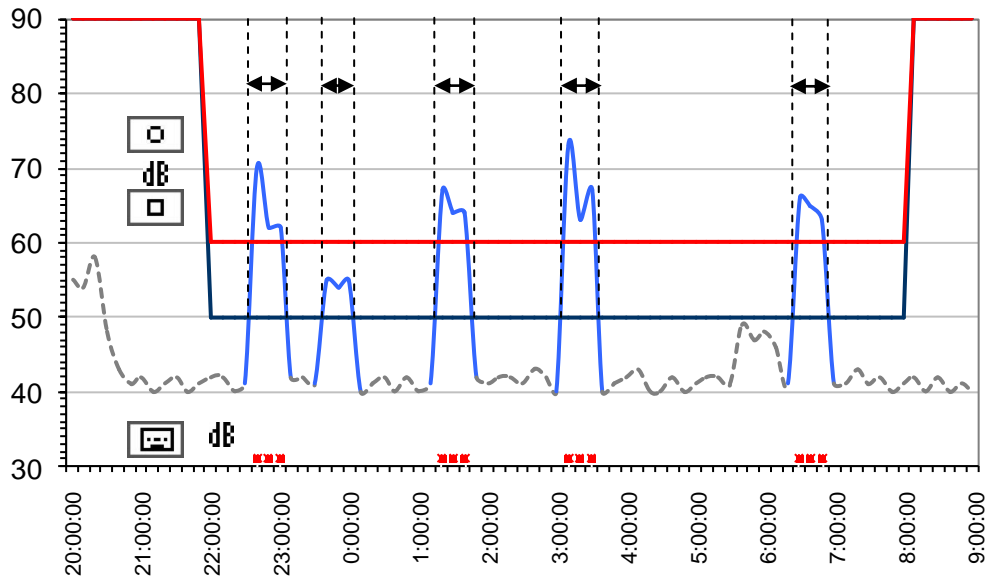

CONTINUOUS MONITORING OF A PORT INFRASTRUCTURE

SITUATION: monitoring the environmental impact of land-based port services: mechanical operations for loading and unloading bulk commodities such as cereals, minerals or industrial salts, or in containers with elevators and conveyors, and maintenance and repair work. You need to identify the activities that infringe the current noise pollution regulations in the port zone.

PROGRAMMING:

				dB				dB				dB
	70.0 dB				70.0 dB				75.0 dB			
	70.0 dB				70.0 dB				75.0 dB			
	60.0 dB				60.0 dB				65.0 dB			
	5 s				5 s				5 s			
					07:00:00		19:00:00		23:00:00			

RESULT: When pressing the SC420 makes recordings of the sound events that exceed the limits set down in the environmental regulations (Day and Evening: 70 dBA; and Night: 60 dBA); it also makes a brief audio recording when these exceed the limit by 5 dBA. This saves memory by not recording audio throughout the sound event, but only doing so at the start to identify its origin.

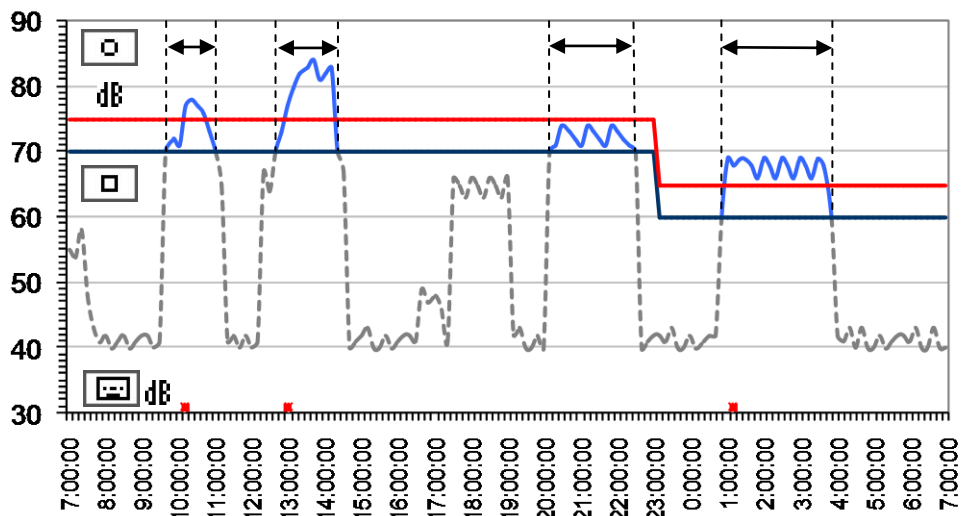

MONITORING THE NOISE GENERATED BY THE LOADING AND UNLOADING OF A TRANSPORT FLEET

SITUATION: Monitoring the noise generated by the tasks of loading and unloading goods onto/from a transport fleet. You need to record noise levels while vehicles are present. To this end, we have installed a presence-detecting sensor that connects to the SC420 [1 → No vehicles present; 0 → Vehicles present].

PROGRAMMING:



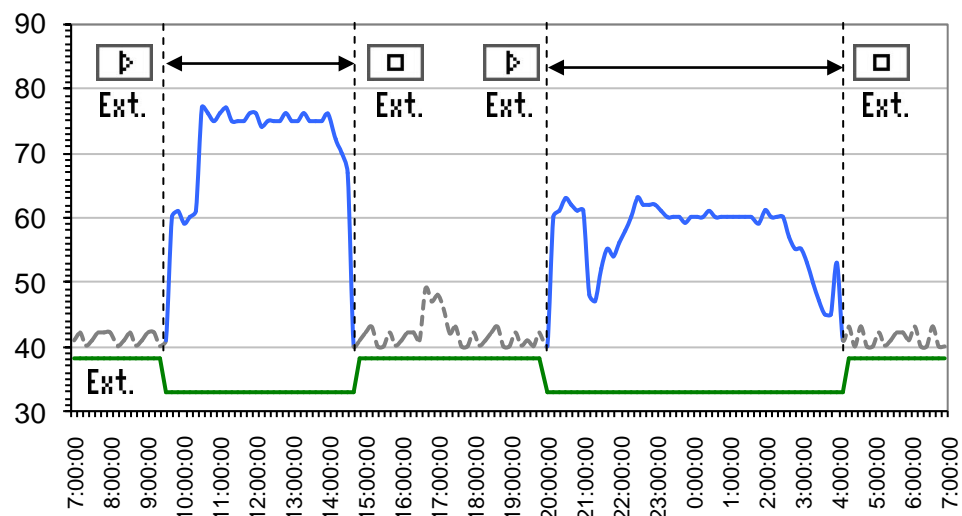

RESULT: When pressing , the SC420 waits for the sensor to detect the presence of vehicles before starting a recording of the time the vehicles are present.







From the settings sub-menu you can configure all the services provided by the SC420: functions displayed, functions saved in memory, automatisms settings, date and time, sensitivity, Bluetooth® wireless communication, etc.





15.1 Accessing the settings sub-menu

Once the SC420 is switched on, ensure there is no measurement in progress  and press . The menu screen  will be displayed automatically.

The cursor (highlighted option) will be at the first option in the menu area. Press

 and  to select the SETTINGS option  and press .

15.2 Navigating through the settings sub-menu

To select an option from the settings sub-menu, use the selector keys    .

Pressing  accepts the selected option or the changes made.









Pressing  takes you to the previous menu screen, without accepting the changes.

Pressing  takes you directly to the current measurement mode, without accepting the selected option or the changes made.

In the map area icons indicate the current location within the different menu screens of the SC420.

15.3 Settings sub-menu

The settings sub-menu features the following options:

OPTION	FUNCTION
 MEASUREMENT	Allows you set the measurement parameters for the different modes.
 RECORDING	Allows you set the functions saved in recordings, for different measurement modes.
 AUTOMATISMS	Allows you set the automatic start/stop measurement/recording and automatic audio recording functions.
 DATE AND TIME	Allows you adjust the date and time displayed on the SC420 as well as consult the date/time change log.
 SENSITIVITY ADJUSTMENT	Allows you adjust the sensitivity of the SC420 as well as consult the sensitivity adjustment log.
 CONTRAST	Allows you adjust the screen contrast.
 AC OUTPUT	Allows you configure the SC420's AC output.
 BLUETOOTH® WIRELESS/PRINTER COMMUNICATION	Allows you enable and disable Bluetooth® wireless and serial printer communication.

15.3.1 MEASUREMENT option



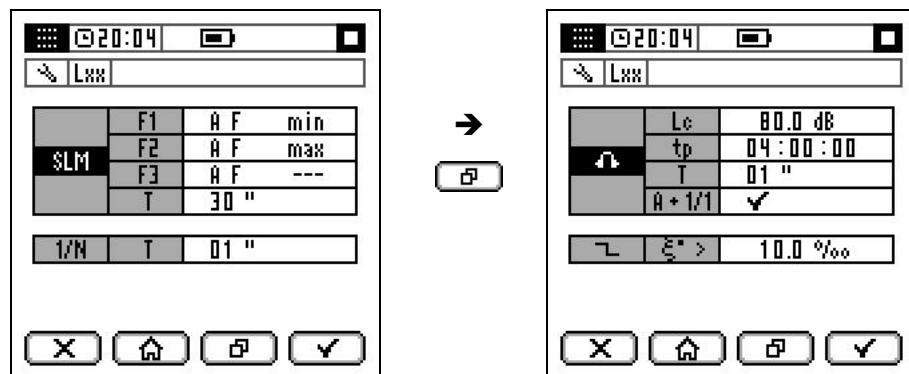



This option lets you set various parameters related to the functions measured in each mode. When selecting it, the following screens will appear:







Sound level meter mode
Analyser mode 1/1 and 1/3

Occupational noise mode
Reverberation time mode

Pressing  takes you to the next screen.

Using the  and  selector keys, select the mode to be configured and press . Choose the parameter you want to set with the  and  keys, and press .

Use  and  to modify the parameter value. If the parameter has several fields, use  and  to access them.

To go back, press .

Press  to accept the changes made.

SOUND LEVEL METER MODE (SLM)

Use this option to set the following parameters:

- The 3 functions that appear simultaneously on the preference screen.
- The consecutive integration time for the functions L_{XT} and L_{XIT} .

To modify the F1 (large figures) and F2 and F3 (small figures) functions, follow the procedure below:

- Choose the frequency weighting: A, C or Z.
- Select the acoustic function: Fast (F), Slow (S), Impulse (I), Equivalent level with programmable integration time (T), Equivalent level with total integration time (t), Noise exposure level (E), Peak Level (peak), Equivalent level of impulse function with programmable integration time (IT), or Equivalent level of impulse function with total integration time (It).
- Choose the function value: instantaneous (---), minimum (min) or maximum (max).

For more information on the names of the different acoustic functions, please consult chapter 23.

To modify the parameter T, choose its numerical value and the time units: seconds ("), minutes (') or hours (h).





ANALYSER MODE 1/1 and 1/3

Select this option to set the integration time (T) used in the consecutive assessment of the spectral and global levels, in the spectral analysis modes 1/1 and 1/3.

To modify the parameter T, choose its numerical value and the time units: seconds ("), minutes (') or hours (h).

OCCUPATIONAL NOISE MODE

Use this option to set the following parameters:

- Criterion level (L_C): level that would correspond to 100% of DOSE if measuring for 8 hours.
- Time of projection (tp): predicted noise exposure time.
- Integration time (T). Integration time for the measurement of the equivalent continuous sound pressure level. The occupational noise mode saves the time log for the parameters (L_{Cpeak} , L_{AT} , L_{CT} and L_{Toct}).
- Whether you are applying the frequency weighting to the spectral analysis in octave bands   or not  .

To modify the parameter L_C , enter its numerical value in dB.

To modify the parameter t_p , enter its numerical value in hh:mm:00.

To modify the parameter T , choose its numerical value and the time units: seconds ("), minutes (') or hours (h).

To modify the parameter (A+1/1), choose if you wish to measure using frequency weighting A simultaneously with the octave filters, or if you do not wish to use it. Place the cursor in the corresponding box and use and to select the desired option.

REVERBERATION TIME MODE

Use this option to set the limit value for the ξ parameter, which the device uses to decide whether the decay curve is far from being regular line. This value only applies to the measurement of reverberation time using the interrupted noise method.

15.3.2 RECORDING option

This option sets the periodicity and functions to be stored by the SC420 when making a recording. It also sets how the device behaves when running on USB power and that power source is interrupted. When selecting the recording option, the following screen appears:

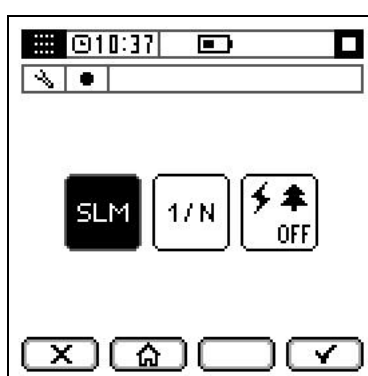

Use and to choose one of the following options and press .

SOUND LEVEL METER RECORDING OPTION SLM

This option sets the periodicity and data the SC420 will store when making a recording in sound level meter mode (see 16.2).

Selecting it will display the following screen:

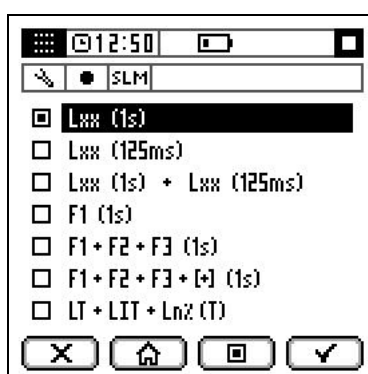

Highlighted and marked as , the option that is currently configured will appear. Use and to select the desired option and press to select the highlighted option. This will appear marked as . Press to accept the changes made.

SPECTRUM ANALYSER RECORDING OPTION 1/N

This option sets the periodicity and data the SC420 will store when making a recording in analyser modes 1/1 and 1/3 (see 16.2).

Selecting it will display the following screen:

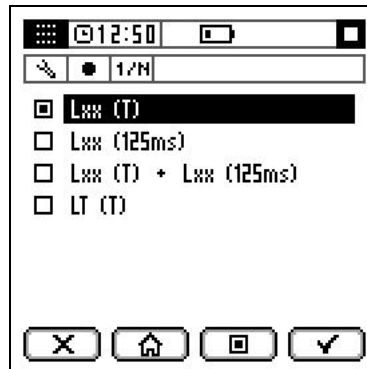

Highlighted and marked as , the option that is currently configured will appear. Use and to select the desired option and press to select the highlighted option. This will appear marked as . Press to accept the changes made.

POWER FOR ENVIRONMENTAL MONITORING RECORDING OPTION



When selecting this option, the current status (option highlighted) of environmental monitoring will appear: OFF or ON.

To change it, use and press .

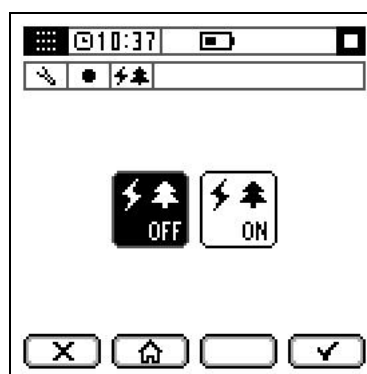





For more information on the 'Power for environmental monitoring' option, please see 7.3.

When the SC420 is switched off, this option is left in the status set. This means that if it is set to ON, when the SC420 is next switched on, the 'power for environmental monitoring' option will be activated.

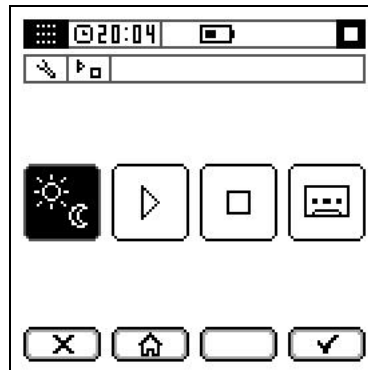

15.3.3 AUTOMATISMS option

Use this option to set the parameters for automatic start/stop measurement/recording or automatic audio recordings. Selecting it will display the following screen:









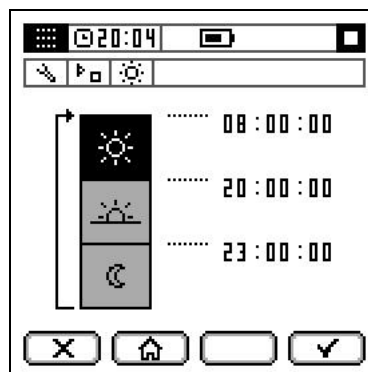

Use  and  to choose one of the following options and press .

DEN TIME INTERVALS

Use this option to set the beginning and end for the three time intervals into which the day is divided: ,  and . Selecting it will display the following screen:



Use  and  to select the period you wish to set the start for HH:mm and press . Set the hour using  and , press  and with  and  set the minutes.

The end of one period coincides with the beginning of the following period.

Press  to accept the changes made.

AUTOMATIC START MEASUREMENT/RECORDING OPTION

Use this option to set the type of automatic start: without setting (--), for a specific time () by waiting time () by DEN level (dB) or by external digital input (Ext.) (see 14.6.1). Selecting it will display the following screen:

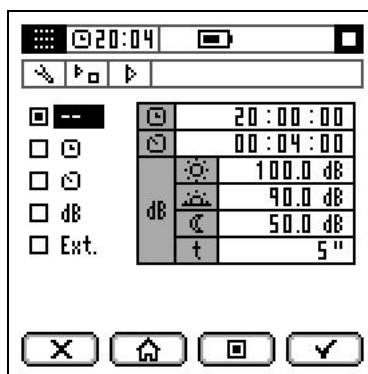

Highlighted and marked as , the option that is currently configured will appear. Use and to select the desired option and press to select the highlighted option. This will appear marked as .

Press to set the parameters for each option. Use and to adjust the parameter value. If the parameter has several fields, use and to access them.

- For a specific time : enter the value of the start time in hh:mm:00.
- For waiting time : enter the value of the time in hh:mm:00. (If you enter 00:00:00, the device will not recognise this configuration and will maintain the previous values).
- For DEN level : Use and to select the DEN period or start time (t). Press to proceed and use and to set the threshold level in decibels for each time interval and the trigger time between 1 and 10 seconds.

Press to accept the changes made.

AUTOMATIC STOP MEASUREMENT/RECORDING OPTION

Use this option to set the type of automatic stop: without setting (--), for a specific time (), by waiting time (), by DEN level () or by external digital input (Ext.). Here you can also set the repeat option (see 14.6.2). Selecting it will display the following screen:

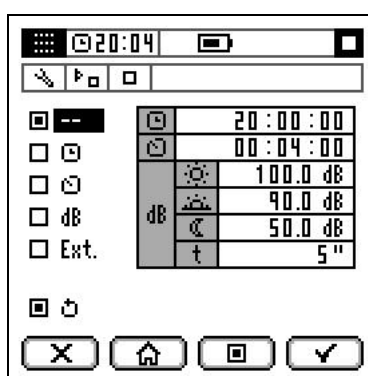

Highlighted and marked as , the option that is currently configured will appear. Use and to select the desired option and press to select the highlighted option. This will appear marked as .

Press to set the parameters for each option. Use and to adjust the parameter value. If the parameter has several fields, use and to access them.

- For a specific time **☒**: enter the value of the stop time in hh:mm:00.
- For a waiting time **☒**: enter the value of the time in hh:mm:00. (If you enter 00:00:00, the device will not recognise this configuration and will maintain the previous values).
- For DEN level **dB**: Use **▲** and **▼** to select the DEN period or start time (t). Press **▶** to proceed and use **▲** and **▼** to set the threshold level in decibels for each time interval and the trigger time between 1 and 10 seconds.

The repeat option **☑** **↺** can be activated on this screen.

To modify the status of the repeat option, access it using **▲** and **▼** and press **☑** to select it (on) or deselect it (off).

Press **☑** to accept the changes made.

AUTOMATIC AUDIO RECORDING OPTION **☒** **▶** **☑** **☒**

Use this option to set the automatic audio recording: without setting (--), by time between recordings (**☒**), by DEN level (dB) or by external digital input (Ext.) (see 14.6.3). Selecting it will display the following screen:

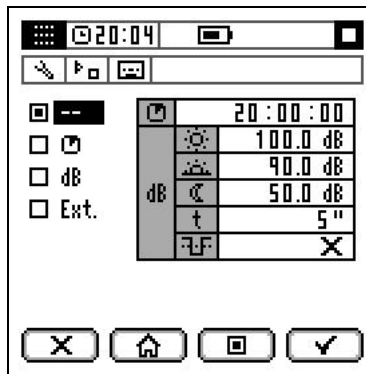

Highlighted and marked as **☑**, the option that is currently configured will appear. Use **▲** and **▼** to select the desired option and press **☑** to select the highlighted option. This will appear marked as **☑**.







Press **▶** to set the parameters for each option. Use **▲** and **▼** to adjust the parameter value. If the parameter has several fields, use **◀** and **▶** to access them.

- For time between recordings **☒**: enter the value of the time in hh:mm:00.
- For DEN level **dB**: use **▲** and **▼** to select the DEN period, the start time (t) or the new event option. Press **▶** to proceed and use **▲** and **▼** to set the threshold level in decibels for each time interval, the trigger time between 1 and 10 seconds and the new event option (see 14.6.4).

Press **☑** to accept the changes made.

15.3.4 DATE AND TIME option

This option lets you adjust the date and time of the SC420, which the SC420 uses to reference measurements, recordings and audio recordings.

To change the current setting, choose between DATE  and TIME  and press . You can make the adjustment using  and  (to modify a value) and  and  (to change parameter).

Finally, to validate the changes press . A new record will be added to the date change history.

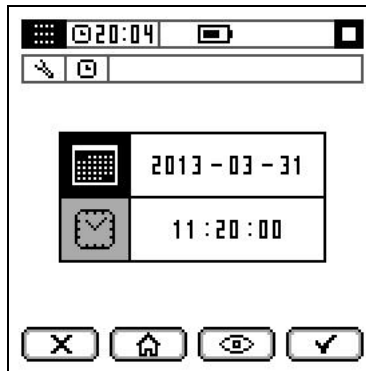

Pressing  takes you to the date change log, where the last 4 changes made can be consulted.

For each change, the number of the change (increasing in consecutive order), the date and time before change and the new date and time after the change are given.

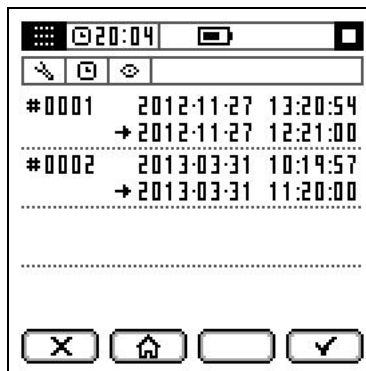

15.3.5 MICROPHONE SETTING option

This option lets you select the sound level correction, indicate the microphone model to be used in the measurement, and adjust the sensitivity of the SC420.

NOTE: The sensitivity of the SLM must only be adjusted by authorised, technically qualified personnel. Readjustment of the sensitivity entails the loss of traceability in the calibration of the instrument.

It is recommended that pre- and post-measurement checking using a calibrator is performed as described in 10.1.

When selecting this option, the screen will display the sound pressure level measured by the *SC420*, along with the following parameters: the sound field correction, microphone model and sensitivity setting level currently configured.



Using and , select the parameter to be set. The available options are:



Sound field correction



Microphone model



Sensitivity setting



Sound field correction. You can choose between FF - free field (without correction) and DF - diffuse field. Use and to select the desired option.



Microphone model. You can choose one of the 3 models of microphone available (C-130, C140 and C240). Use and to select the desired option.



Sensitivity setting. To adjust the sensitivity, you will need to use an acoustic calibrator. Before making the adjustment, carefully read subsection 10.1 and find the value to which the *SC420* should be adjusted.

Ensure the calibrator is correctly fitted and switched on. To adjust the sound level meter reading to the value calculated with the pressure-free field correction (see 10), use and .

Finally, to validate the changes press .

If the sensitivity setting has been modified, a new record will be added to the sensitivity change log.

Pressing takes you to the sensitivity change log, where the last 4 changes made can be consulted.

For each change, the number of the change (increasing in consecutive order), the date and time of the change and the value of the sensitivity setting level are given.

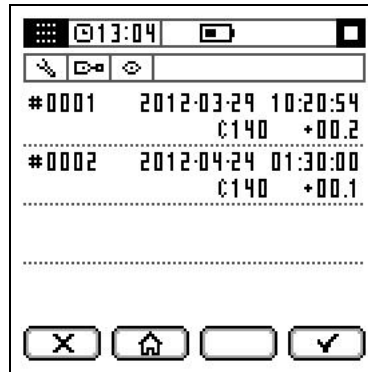

15.3.6 CONTRAST option

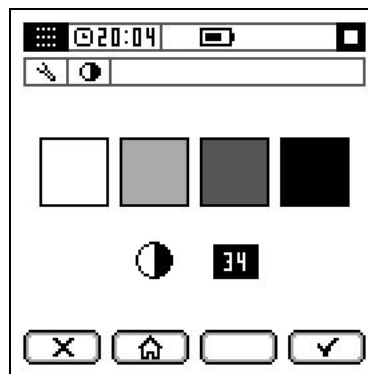

When selecting this option, the screen displays the level of contrast in numerical form and a sample of 4 colours, to serve as a reference while choosing the appropriate level of contrast.

To change the setting, use  and  and press .



15.3.7 AC OUTPUT option

The AC output of the SC420 is directly proportional to the signal obtained at the preamplifier output. This option lets you set the gain for this output: 0 dB or 40 dB.

The setting highlighted is the current one; if you wish to change it, use  and  and press .

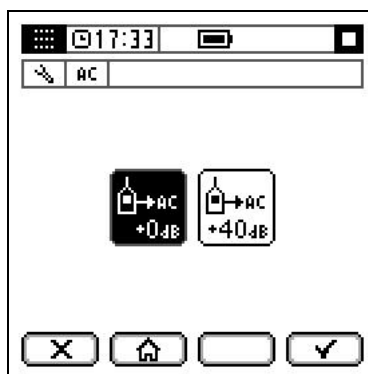

15.3.8 BLUETOOTH® wireless communication/PRINTER option



When selecting this option, the current status for the RS-232 communication will appear: Bluetooth® wireless communication ON, printer serial communication with a printer ON, or OFF if both of communications switched off (RS-232 communication is free).

To change it, use and and press .

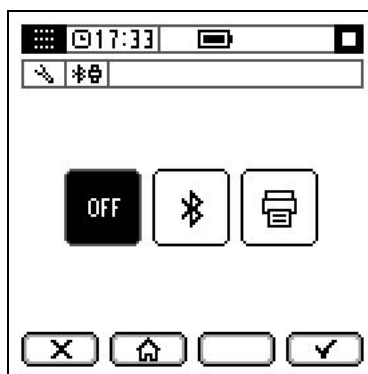

When Bluetooth® wireless communication is enabled, the Bluetooth symbol will be displayed in the indicator area. When the serial communication with a printer is enabled, the printer symbol will be displayed in the indicator area.

For more information on Bluetooth® wireless communication, see 17.2.4.

For more information on serial communication with a printer, see 17.2.2.

When the SC420 switches on, the RS-232 communication is in the state programmed.

The Bluetooth® trademark is the property of Bluetooth SIG, Inc.

NOTE: To preserve the batteries, disable Bluetooth when it is not needed.

The SC420 can store the values of the functions measured on the memory card. When the device is switched off, the data saved are not lost and can be recovered, viewed and deleted directly on the SC420 itself, or they can be transferred to a computer or imported from the memory card to a computer.





Two kinds of records can be saved in the memory:

- The final results of a measurement.
- Continuous recordings of the functions measured together with the associated audio files.

If making a recording, the time history of the functions set and, at the end of the measurement, the final results are automatically saved to memory.

Another option is to take a measurement and then save the results. This record will not contain the time history of the functions, only the final results.

16.1 Saving a final result

To save a final result to memory (not saving the time log of the measurement), after measuring , press . The menu screen  will be displayed automatically. The cursor (highlighted option) will already be at the SAVE RESULT option  in the menu area; press .

The SC420 will save in memory the final result of all the functions measured and will return to the measurement screen. In the memory area, the number of the register where the final result has been saved will appear.



The SC420 can save a maximum of 64000 final results, regardless of the measurement mode.

NOTE: It is only possible to save final results if there is a memory card inserted in the slot, with available space.

Below is the breakdown of the functions saved for each measurement mode:

TIME BASE	SOUND LEVEL METER FINAL RESULT FUNCTIONS
t : Measurement time	L _{Xt} , L _{XE} , L _{Xpeak} , L _{XIt} , L _{nT} , L _{AF5t} L _{XFmax} , L _{XSmax} , L _{XImax} , L _{XFmin} , L _{XSmin} , L _{Xlmin} , L _{XTmax} , L _{XTmin} ,
T: Last complete integration interval	L _{XT} , L _{XIT} , L _{nT} , L _{AF5T}
1s: Last second	L _{XF} , L _{XS} , L _{XI} , L _{X1s} , L _{XFmax1s} , L _{XSmax1s} , L _{XImax1s} , L _{XFmin1s} , L _{XSmin1s} , L _{Xlmin1s} , L _{Xpeak1s}
Date and time of start of measurement, measurement and integration time	

X: indicates the frequency weighting (A, C and Z).

n: 1%, 5%, 10%, 50%, 90%, 95% and 99%

TIME BASE	ANALYSER 1/1 FINAL RESULT FUNCTIONS
t : Measurement time	L _{Xt} , L _{Xpeakt} , L _{Ant} L _{ft} , L _{fnt}
T: Last complete integration interval	L _{XT} , L _{XpeakT} , L _{AnT} L _{fT} , L _{fnt}
Date and time of start of measurement, measurement and integration time	

X: indicates the frequency weighting (A, C and Z).

f: indicates the octave band filter with central frequency of 31.5, 63, 125, 250, 500, 1000 (1k), 2000 (2k), 4000 (4k), 8000 (8k) and 16000 (16k) Hz.

n: 1%, 5%, 10%, 50%, 90%, 95% and 99%

TIME BASE	ANALYSER 1/3 FINAL RESULT FUNCTIONS
t : Measurement time	L _{Xt} , L _{ft} , L _{AFmaxt} , L _{ASmaxt} , L _{Almaxt} , L _{Alt} , L _{Ant}
T: Last complete integration interval	L _{XT} , L _{fT} , L _{AFmaxT} , L _{ASmaxT} , L _{AlmaxT} , L _{AIT} , L _{AnT}
Date and time of start of measurement, measurement and integration time	

X: indicates the frequency weighting (A, C and Z).

f: indicates the octave band filter with central frequencies of 10, 12.5, 16, 20, 25, 31.5, 40, 50, 63, 80, 100, 125, 160, 200, 250, 315, 400, 500, 630, 800, 1000 (1k), 1250 (1.25k), 1600 (1.6k), 2000 (2k), 2500 (2.5k), 3150 (3.15k), 4000 (4k), 5000 (5k), 6300 (6.3k), 8000 (8k), 10000 (10k), 12500 (12.5k), 16000 (16k) and 20000 (20k) Hz.

n: 1%, 5%, 10%, 50%, 90%, 95% and 99%

RT 1/1 and RT 1/3 FINAL RESULT FUNCTIONS (interrupted noise method)

L_{Nf} , Δf , T_{30f} , T_{20f} , ξ_{T20f} , ξ_{T30f} , C_f , $B \cdot T_{20f}$, $B \cdot T_{30f}$, decay curve (f)

Date and time of beginning of measurement.

f: indicates the octave band filter with central frequencies of 63, 125, 250, 500, 1000 (1k), 2000 (2k) and 4000 (4k)Hz. or the third octave band filter with central frequencies of 50, 63, 80, 100, 125, 160, 200, 250, 315, 400, 500, 630, 800, 1000 (1k), 1250 (1.25k), 1600 (1.6k), 2000 (2k), 2500 (2.5k), 3150 (3.15k), 4000 (4k) and 5000 (5k) Hz depending on **L1** or **L3** mode.

RT 1/1 and RT 1/3 FINAL RESULT FUNCTIONS (integrated impulse response method)

L_{Nf} , Δf , T_{30f} , T_{20f} , ξ_{T20f} , ξ_{T30f} , C_f , $B \cdot T_{20f}$, $B \cdot T_{30f}$, impulse response (f), decay curve (f)

Date and time of beginning of measurement.

f: indicates the octave band filter with central frequencies of 63, 125, 250, 500, 1000 (1k), 2000 (2k) y 4000 (4k)Hz, or the third octave band filter with central frequencies of 50, 63, 80, 100, 125, 160, 200, 250, 315, 400, 500, 630, 800, 1000 (1k), 1250 (1.25k), 1600 (1.6k), 2000 (2k), 2500 (2.5k), 3150 (3.15k), 4000 (4k) y 5000 (5k) Hz depending on the mode **L1** or **L3**.

TIME BASE OCCUPATIONAL NOISE FINAL RESULT FUNCTIONS

t : Measurement time L_{At} , L_{Ct} , L_{Xft} , L_{Cpeakt} , ($L_{EX,8h}$, E , $DOSE$, $L_{EX,8hp}$, E_p , $DOSE_p$)*

T: Last complete integration interval L_{AT} , L_{CT} , L_{fT} , L_{CpeakT}

Date and time of start of measurement, measurement and integration time

f: indicates the octave band filter with central frequencies of 63, 125, 250, 500, 1000 (1k), 2000 (2k), 4000 (4k) and 8000 (8k) Hz. All functions are measured simultaneously with all octave band filters.

X: with or without frequency weighting A (15.3.1).

*The functions $DOSE$, $DOSE_p$, $L_{EX, 8h}$, $L_{EX, 8h p}$, E and E_p are not saved but they are evaluated according to the L_C and t_p values each time they are recovered.

TIME BASE FFT ANALYSER FINAL RESULT FUNCTIONS

t: Measurement time L_{Xft} (10,000 lines)

Date and time of beginning of measurement

Measurement time

f: indicates the constant band filter between 0 and 20000 (20k) Hz.

X: with frequency weighting A and Z.

10,000 lines (2 Hz/line).

The total FFT time that can be recorded on 1 GB of memory is 16 days and 13 hours in FFT mode.

For the name and definition of each of the functions measured, please see chapter 23.

16.2 Making a recording

A recording consists of making a measurement and storing a series of functions in the memory with a defined periodicity. At the end of the recording, the final results are also saved.

NOTE: It is only possible to make a recording for the following modes: SOUND LEVEL METER, ANALYSER 1/1, ANALYSER 1/3, OCCUPATIONAL NOISE, AUDIO (analysis quality and listening quality), and VOICE COMMENTS.

A memory card with available space must also be inserted in the slot.



To make a recording: in AUDIO mode (analysis quality), please see 13.9.1 and 14.5, for the VOICE COMMENTS mode please see 14.4, for other modes please see 11.3

16.2.1 Types of recording

These functions and the periodicity are specified, for each mode, in the recording setting. The main difference between the various types of recording lies in the compromise "quantity of functions/storage time".

NOTE: When making a recording, as well as the time log (of the parameters set out below), the device also saves the final results to memory (see 16.1).

RECORDING IN SOUND LEVEL METER MODE

Use the SOUND LEVEL METER RECORDING   SLM option (see 15.3.2) to set the periodicity and data of the time log that the SC420 will save when making a recording in sound level meter mode, in addition to the final results. Seven possibilities are available:

These 3 types of recording are conceived for short-duration measurements.

- **LXX (1s):** saves all the functions measured every second:

TIME BASE	LXX (1s) SOUND LEVEL METER RECORDING FUNCTIONS:
t : Measurement time	L _{Xt} , L _{XE} , L _{Xpeak} , L _{XIt} , L _{nt} , LAF5t L _{XFmax} , L _{XSmax} , L _{XImax} , L _{XFmin} , L _{XSmin} , L _{XImin}
T: Programmed integration time	L _{XT} , L _{XTmax} , L _{XTmin} , L _{XIT} , L _{nT} , LAF5T
1s	L _{XF} , L _{XS} , L _{XI} , L _{X1s} , L _{XFmax1s} , L _{XSmax1s} , L _{XImax1s} , L _{XFmin1s} , L _{XSmin1s} , L _{XImin1s} , L _{Xpeak1s}

- **LXX (125ms):** saves all the functions measured every 125 ms:

TIME BASE	LXX (125ms) SOUND LEVEL METER RECORDING FUNCTIONS:
125ms	LX125ms, LXpeak125ms, LXF125ms, LXS125ms, LXI125ms

- **LXX (1s) + LXX (125ms):** saves all the 1s functions and all the 125 ms "short" functions:

TIME BASE	LXX (1s) + LXX (125ms) SOUND LEVEL METER RECORDING FUNCTIONS:
t : Measurement time	LXt, LXE, LXpeak, LXIt, Lnt, LAF5t LXFmax, LXSmax, LXImax, LXFmin, LXSmin, LXImin
T: Programmed integration time	LXT, LXTmax, LXTmin, LXIT, LNT, LAF5T
1s	LXF, LXS, LXI, LX1s, LXFmax1s, LXSmax1s, LXImax1s, LXFmin1s, LXSmin1s, LXImin1s, LXpeak1s
125ms	LX125ms, LXpeak125ms, LXF125ms, LXS125ms, LXI125ms

These types of recording are conceived for long-duration measurements, such as studies of environmental noise, traffic noise, etc.

- **F1 (1s):** saves the main function programmed on the preferential screen second by second:

TIME BASE	F1 (1s) SOUND LEVEL METER RECORDING FUNCTIONS:
1s	F1

- **F1 + F2 + F3 (1s):** saves the 3 functions programmed on the preference screen second by second:

TIME BASE	F1 + F2 + F3 (1s) SOUND LEVEL METER RECORDING FUNCTIONS:
1s	F1, F2, F3

This type of recording is very practical in that it saves the basic sound-measurement functions: Short Leq, Fast every 125 ms (statistical information may be calculated from here), the peak level and three set sound-measurement functions.

- **F1 + F2 + F3 + [+] (1s):** saves the following functions every second:

TIME BASE	F1 + F2 + F3 + [+] (1s) SOUND LEVEL METER RECORDING FUNCTIONS:
1s	LCpeak1s, F1, F2, F3
125ms	LAF125ms, LA125ms

- **LT + LIT + Ln% (T):** saves the following functions every T (integration time):

TIME BASE	LT + LIT + Ln% (T) SOUND LEVEL METER FUNCTIONS:
T: Programmed integration time	L_{XT} , L_{XIT} , L_{nT}

X: indicates the frequency weighting (A, C and Z).



n: 1%, 5%, 10%, 50%, 90%, 95% and 99%

The following table shows the storage capacity per 1 GB of memory for the different types of recording in sound level meter mode:

TYPE OF RECORDING 	STORAGE CAPACITY per 1 GB
LXX (1s):	2 months 12 days
LXX (125ms):	1 month 21 days
LXX (1s) + LXX (125ms):	1 month
F1 (1s):	6 years 8 months
F1 + F2 + F3 (1s):	3 years 9 months
F1 + F2 + F3 + [+] (1s):	9 months 17 days
LT + LIT + Ln% (T):	1 year 2 months

NOTE: These capacities will be reduced if associated audio files (listening quality) are recorded during the measurement recording.

RECORDING IN 1/1 ANALYSER MODE

Use the SPECTRUM ANALYSER RECORDING option   (see 15.3.2) to set the periodicity and data of the time log that the SC420 will save when making a recording in 1/1 analyser mode, in addition to the final results. There are 4 possibilities:

This type of recording is conceived for long-duration measurements, such as studies of environmental noise and traffic noise, for which spectral information on the measured noise is needed.

- **LXX (T):** once each integration period (T) has come to an end, the following values are stored in the memory:

TIME BASE	1/1 LXX (T) ANALYSER RECORDING FUNCTIONS:
T: Programmed integration time	L_{XT} , L_{XpeakT} , L_{AnT} L_{fT} , L_{fnT}

These two types of recordings are especially designed to obtain spectral information that is highly detailed in terms of time. These types are perfect for detecting and monitoring noise sources such as vehicle traffic on roads and air traffic at airports.

- **LXX (125ms):** saves the following functions every 125 ms:

TIME BASE	LXX (125ms) ANALYSER 1/1 RECORDING FUNCTIONS:
125 ms	L_{X125ms} , $L_{Xpeak125ms}$, L_{f125ms}

- **LXX (T) + LXX (125ms):** saves the '125 ms functions' every 125 ms and the 'T functions' every T:

TIME BASE	LXX (T) + LXX (125ms) ANALYSER 1/1 RECORDING FUNCTIONS:
T: Programmed integration time	L_{XT} , L_{XpeakT} , L_{AnT} L_{fT} , L_{fnT}
125 ms	L_{X125ms} , $L_{Xpeak125ms}$, L_{f125ms}

- **LT (T):** once each integration period (T) has come to an end, the following values are stored in the memory:

TIME BASE	LT(T) ANALYSER 1/1 RECORDING FUNCTIONS:
T: Programmed integration time	L_{XT} , L_{fT}

X: indicates the frequency weighting (A, C and Z).

f: indicates the octave band filter with central frequency of 31.5, 63, 125, 250, 500, 1000 (1k), 2000 (2k), 4000 (4k), 8000 (8k) and 16000 (16k) Hz.



n: 1%, 5%, 10%, 50%, 90%, 95% and 99%

The following table shows the storage capacity per 1 GB of memory for the different types of recording in 1/1 analyser mode.

TYPE OF RECORDING 1/1	STORAGE CAPACITY per 1 GB	
LXX (T):	T=1s	26 days
LXX (125ms):	T=125ms	1 month 15 days
LXX (T) + LXX (125ms):	T=1s	26 days
LT (T):	T=1s	1 year 1 month

NOTE: These capacities will be reduced if associated audio files (listening quality) are recorded during the measurement recording.

RECORDING IN 1/3 ANALYSER MODE

Use the SPECTRUM ANALYSER RECORDING   1/n option (see 15.3.2) to set the periodicity and data of the time log that the SC420 will save when making a recording in 1/3 analyser mode, in addition to the final results. There are 3 possibilities:

This type of recording is conceived for long-duration measurements, such as studies of environmental noise and traffic noise, which require detailed spectral information of the measured noise together with global functions.

- **LXX (T)**: once each integration period (T) has come to an end, the following values are stored in the memory:

TIME BASE	LXX (T) ANALYSER 1/3 RECORDING FUNCTIONS:
T: Programmed integration time	L_{XT} , L_{AIT} , L_{AFmaxT} , L_{ASmaxT} , L_{AlmaxT} , L_{fT}

These two types of recording are specially designed to obtain highly detailed time and spectrum information. They are also ideal for the detection of tonal components.

- **LXX (125ms)**: saves the following functions every 125 ms:

TIME BASE	LXX (125ms) ANALYSER 1/3 RECORDING FUNCTIONS:
125 ms	L_{X125ms} , $L_{AI125ms}$, $L_{AFmax125ms}$, $L_{ASmax125ms}$, $L_{Almax125ms}$, L_{f125ms}

- **LXX (T) + LXX (125ms)**: saves the '125 ms functions' every 125 ms and the 'T functions' every T:

TIME BASE	LXX (T) + LXX (125ms) ANALYSER 1/3 RECORDING FUNCTIONS:
T: Programmed integration time	L_{XT} , L_{AIT} , L_{AFmaxT} , L_{ASmaxT} , L_{AlmaxT} , L_{fT} , L_{AnT}
125 ms	L_{X125ms} , $L_{AI125ms}$, $L_{AFmax125ms}$, $L_{ASmax125ms}$, $L_{Almax125ms}$, L_{f125ms}

- **LT (T)**: once each integration period (T) has come to an end, the following values are stored in the memory:

TIME BASE	LT(T) ANALYSER 1/3 RECORDING FUNCTIONS:
T: Programmed integration time	L_{XT} , L_{fT}

X: indicates the frequency weighting (A, C and Z).

n: 1%, 5%, 10%, 50%, 90%, 95% and 99%

f: indicates the third octave band filter with central frequencies of 10, 12.5, 16, 20, 25, 31.5, 40, 50, 63, 80, 100, 125, 160, 200, 250, 315, 400, 500, 630, 800, 1000 (1k), 1250 (1.25k), 1600 (1.6k), 2000 (2k), 2500 (2.5k), 3150 (3.15k), 4000 (4k), 5000 (5k), 6300 (6.3k), 8000 (8k), 10000 (10k), 12500 (12.5k), 16000 (16k) and 20000 (20k) Hz.

The following table shows the storage capacity per 1 GB of memory for the different types of recording in 1/3 analyser mode.

TYPE OF RECORDING f	STORAGE CAPACITY per 1 GB	
LXX (T)	T=1s	4 months 5 days
LXX (125ms):	T=125ms	18 days 22 hours
LXX (T) + LXX (125ms):	T=1s	16 days 12 hours
LT (T):	T=1s	5 months 11 days

NOTE: These capacities will be reduced if associated audio (listening quality) files are recorded during the measurement recording.

RECORDING IN OCCUPATIONAL NOISE MODE

Upon completion of each integration period (T), the occupational noise mode saves the following values in memory, in addition to the final results:

TIME BASE	OCCUPATIONAL NOISE RECORDING FUNCTIONS:
T: Programmed integration time	L_{AT} , L_{CT} , L_{CpeakT} , L_{XfT} , ($L_{EX,8h}$, E, DOSE, $L_{EX,8hp}$, E_p , DOSE _p)*

f: indicates the octave band filter with central frequencies of 63, 125, 250, 500, 1000 (1k), 2000 (2k), 4000 (4k) and 8000 (8k) Hz. All functions are measured simultaneously with all octave band filters.

X: With or without frequency weighting A (see 15.3.1).

*The functions DOSE, DOSE_p, LEX_{8h}, LEX_{8hp}, E and E_p are not saved but they are evaluated according to the L_C and t_p values each time they are recovered.

The following table shows the storage capacity per 1 GB of memory in occupational noise mode:

STORAGE CAPACITY per 1 GB	
T= 1 s	16 days 16 hours

NOTE: These capacities will be reduced if associated audio files are recorded during the measurement recording (listening quality).

RECORDING IN AUDIO MODE (analysis quality)

STORAGE CAPACITY per 1 GB

2 hours of audio (analysis quality)

AUDIO RECORDING (listening quality)

STORAGE CAPACITY

64000 records

RECORDING VOICE COMMENTS

STORAGE CAPACITY

64000 records

NOTE: The storage times for each type of recording correspond to one single recording, until the memory is completely full.

The SC420 has capacity for up to 64000 records (final results or recordings) of any type.

If you try to save data to the memory without the microSD card inserted, **X** appears on the screen, informing you that it is not possible to save the recording.

When the memory is full, no more recordings can be made, nor any final results saved. If this is attempted, the 'MEMORY FULL' message will appear on screen. If the memory reaches its maximum capacity before a recording has finished, data recording will stop, although the measurement will continue. When the measurement is complete, the final result will be stored in the memory.

The **CESVA Lab** application lets you download and delete memory records while the device is measuring.

16.3 Structure of a register

Each time you save a final result or make a recording, the SC420 saves a register in memory.

For each register, the register number, the date and time it was recorded and the type of register are displayed.



REGISTRER NO.			TYPE OF REGISTRER
↓			↓
00004	2012-12-20	13:55:13	T
00005	2012-12-20	13:55:40	C
00006	2012-12-20	13:57:38	c
	↑	↑	
	START DATE	START TIME	





INDICATOR	TYPE OF REGISTER
S	Sound level meter
O	1/1 Analyser
T	1/3 Analyser
C	1/1 Reverberation time by interrupted noise method
c	1/3 Reverberation time by interrupted noise method
I	1/1 Reverberation time by integrated impulse response method
i	1/3 Reverberation time by integrated impulse response method
D	Occupational noise
F	FFT
A	Audio (display unavailable)
N	Voice comments (display unavailable)

Each register corresponds to a folder. This contains the files belonging to the measurement taken and a sub-folder with the audio files associated with that measurement.

If no audio has been recorded during the measurement, the record file will contain the measurement files, but the audio file sub-folder will remain empty. However, if you make a recording in audio mode or record a voice comment, the register file will only contain the sub-folder with the audio file concerned.

16.4 Viewing and deleting registers

To view or delete a record saved on a microSD card, whether a recording or a final result, ensure there is no measurement in progress  and press . The menu screen  will be displayed automatically.

The cursor (highlighted option) will be at the first option in the menu area. Press  and  to select the RECORDS option  and press .

The following screen will then be displayed with a list of the registers saved to memory.

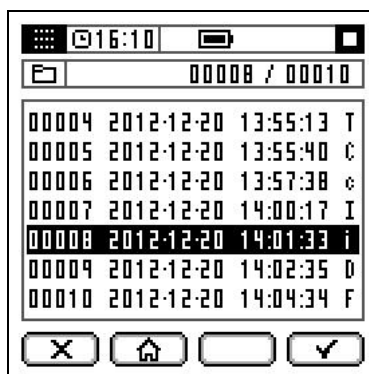

The upper part of the screen will display information on the total number of registers saved to memory and the position of the register currently selected.



Select the register to be deleted or viewed using and and press . (If you hold down or , the cursor will jump to every 7th register). Next, use and to select whether you wish to view or delete the register indicated, and press to validate the action.



Pressing takes you to the initial list.

Pressing takes you directly to the current measurement mode.

16.4.1 Viewing registers



If you have chosen the "view a register" option, the final results of this register will be displayed.

On the right-hand side of the indicator area, the indicator will appear, showing that a register is being viewed. On the left-hand side, you will see the measurement mode of the register being viewed.



Pressing takes you to the initial list containing all the registers in the SC420 memory.





NOTE: Audio registers cannot be viewed. If you try to view them, the screen will display indicating that the option is not available.

16.4.2 Deleting registers

If you have chosen the "delete a register"  option, you will be asked to confirm whether you wish to delete that register. Press  to delete it, or press  to go back to the previous menu without deleting the register.

16.5 Deleting the card memory



To completely erase the card memory of the SC420, ensure there is no measurement in progress  and press . The menu screen  will be displayed automatically.

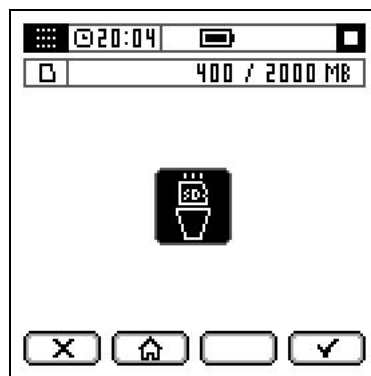

The cursor (highlighted option) will be at the first option in the menu area. Press  and  to select the MEMORY CARD  option and press . The following screen will appear:



At the top of the screen, the space used and the total size of the memory card will be displayed.



Next, press  and accept the DELETE  option. This action will erase all registers (final results and recordings) and audio files on the memory card.

Next, you will be asked to confirm whether you wish to delete the memory card. Press  to confirm, or press  to go back to the previous menu without deleting the card. Deleting the memory card will cause the data to be lost permanently. It is therefore recommended to download the data with the CMD software before deleting the card.

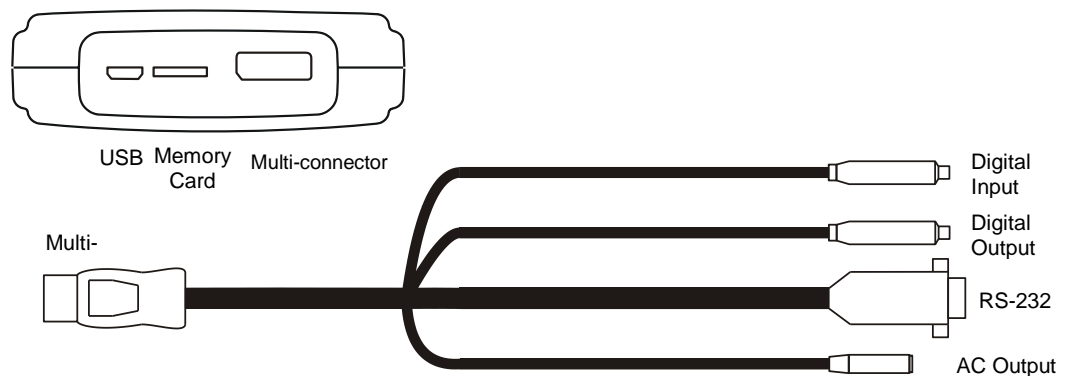

17.1 Digital inputs and outputs and AC output

The following section describes the digital inputs and outputs and the AC output of the *SC420*.

17.1.1 AC Output

The AC (alternating current) output is an analogue output directly proportional to the output of the preamplifier without frequency weighting and is available through the AC OUTPUT connector of the *CN420* cable, when this is connected to the *SC420* multi-connector.

The AC OUTPUT connector is of the mono female mini jack type. To connect it to any audio device (PC sound card, DAT, digital recorder, headphones, etc.), use a standard audio cable (one end must have a mono male mini jack connector and the other end the connector for the audio device).

In order to adapt the dynamic range of the AC output to that of the audio device, you can adjust the gain of the AC output (0 dB for high sound levels or 40 dB for low levels) in the AC OUTPUT option of the SETTINGS menu. Please see 15.3.7.

The AC output lets you listen to the signal being measured by simply connecting your headphones and thus determining whether it is influenced by noises other than those you wanted to measure.

It is also possible to record this signal with an audio recording device for recognition of the sound event measured, or for later analysis by making a calibrated recording using a lossless recording system with enough linear dynamic range for recording. *SC420* already incorporates these two options through its listening quality audio recordings and analysis quality audio recording measuring mode.

A calibrated recording involves recording a calibration signal before and after recording the measurement and without altering recording gains. The 1 kHz and 94 dB tone generated by the CB006 acoustic calibrator is normally used. Subsequently, the measuring instrument's input gain is adjusted to ensure it correctly measures the calibration signal recorded.

17.1.2 Digital input

The digital input of *SC420* is an input that lets you start and stop a data recording according to its status. This input can also be used to insert markers while recording data (see 14.3). It is available through the DIGITAL INPUT on the *CN420* cable (red RCA-type connector), when this is connected to the *SC420* multi-connector.

The *SC420* waits for a change in logical level (from 1 to 0) to start measuring (or recording). And it then waits for another change (from 0 to 1) to stop.

To enable this start and/or end measurement/recording mode, please see 15.3.3. The digital input value is updated every second.

17.1.3 Digital output

The *SC420* digital output is an open collector output that takes logical values when the automatic audio recording threshold is exceeded (see 15.3.3). It is available through the DIGITAL OUTPUT on the *CN420* cable (white RCA-type connector), when this is connected to the *SC420* multi-connector.

The open collector digital output lets you choose the polarisation resistance of the collector and thus fix the output voltage of the high logical level 1. If the threshold is not exceeded, the signal in the digital output keeps the value at 1; if it is exceeded, the value changes to 0.

The thresholds for automatic audio recording are set for each DEN time interval. Please see 15.3.3. The digital output value is updated every second.

17.2 Communicating with a PC, downloading data and communicating with a printer

The SC420 features the following types of communication:

- **Memory card slot:** for inserting a memory card, from which data is downloaded to a PC.
- **Communications inputs/outputs:** for real-time communication, programming and sending the measured functions to a printer.
 - **USB:** Digital communication. Complies with USB rev. 2.0.
 - **RS-232:** Two-way serial digital communication for communication with a personal computer and with a serial printer.
 - **Bluetooth® wireless communication:** Class 1 wireless digital communication.

17.2.1 Memory card

When you make a recording, save final results, record audio or make a recording in analysis quality, this information is saved on the microSD memory card inserted in the slot in the bottom of the SC420.

NOTE: For the device to function correctly, you should use at least a class 4 card.

To download data from the memory card to a PC, you need the **CESVA Lab** software application. There are two ways of performing this process:

- Using the communication inputs/outputs of the SC420: USB, RS-232 serial or Bluetooth® wireless communication (see 4.2).
- By importing the data directly from the card

The latter option requires a computer with a micro SD card reader. There are computers with SD card readers, for which there are micro SD card to SD card adaptors.

The SC420 must be switched off*. Remove the memory card from the SC420 and insert it into the PC's card reader. Using the **CESVA Lab** software, you can now access the SC420 memory card data (see 17.3).

NOTE: This is the quickest way to transfer large quantities of data from an SC420 to a computer.

*If the sound level meter is not switched off when the memory card is removed, data could be lost and the card could even be damaged. **CESVA** accepts no responsibility for the loss of card data.

Please see precautions and warnings to take into account regarding microSD cards.

17.2.2 RS-232 communications

The RS-232 is a two-way serial input/output for digital communication with a computer or with a serial printer, and is available through the RS-232 connector of the *CN420* cable, when this is connected to the *SC420* Multi-connector.

The RS-232 connector is of the DB-9 type. To connect it to a computer, use a serial cable such as the *CN232*. To connect it to a serial printer, use a null modem cable. RS-232 communication facilitates the real-time transmission of measured and saved functions to a computer, as well as programming the *SC420*. This, together with Bluetooth® wireless communication, is a lower-speed transmission option, which is why it is recommended for programming and transferring data in real time. For data downloading, we recommended using USB communication or importing directly from the memory card.

The RS-232 serial input/output is still present in many industrial environments.

Sending to a printer in real time the value of the measured functions is available for sound level meter (S) mode and spectrum analyzer in octave bands (1/1) mode. In sound level meter mode, the value of three programmed functions F1, F2 and F3 are sent every second to the printer.

CESVA SC420 T238592

2014-05-23 12:30:50

	L AF	L At	L CPeak
00:00:01	44.3	49.2	80.1
00:00:02	43.2	47.1	80.1
00:00:03	42.0	46.0	80.1
00:00:04	41.9	45.3	80.1
00:00:05	43.0	44.9	80.1
00:00:06	43.6	44.7	80.1
00:00:07	42.7	44.4	80.1
00:00:08	42.7	44.3	80.1
00:00:09	42.5	44.1	80.1
00:00:10	42.3	44.0	80.1
00:00:11	42.7	43.9	80.1
00:00:12	42.3	43.8	80.1
00:00:13	42.7	43.8	80.1

In 1/1 spectrum analyzer mode, the spectral values and overall values with frequency weightings A and C are sent every T to the printer.

CESVA SC420 T238592

2014-05-23 12:33:17

T 03"

	C	A	16	31.5	63	125	250	500	1k	2k	4k	8k	16k
59.7	44.9	60.6	58.5	54.6	51.2	48.8	42.2	39.0	33.6	30.1	20.2	15.8	
60.3	43.5	62.4	59.4	54.2	50.2	47.6	42.0	35.0	32.4	27.9	24.4	20.7	
59.6	43.8	61.0	58.9	54.2	50.3	47.7	42.9	36.9	30.0	23.1	21.4	19.7	
59.6	42.8	60.5	59.0	54.6	50.8	47.8	41.5	33.3	29.1	22.3	19.4	18.8	
60.7	42.3	62.4	60.8	54.8	50.5	47.5	41.2	32.2	27.4	21.3	19.3	20.5	
59.3	42.3	62.1	57.8	53.9	50.3	47.3	41.2	32.5	27.3	20.8	14.5	13.6	
59.5	42.3	60.2	58.4	54.9	50.0	47.5	41.2	32.1	27.5	21.3	18.9	18.5	
59.6	42.5	62.0	59.2	53.8	50.0	47.4	41.2	32.7	28.7	25.0	19.7	14.7	
59.3	42.6	61.5	58.0	54.1	50.2	47.7	41.3	32.8	28.6	26.2	20.5	15.2	
60.1	42.5	62.5	59.4	54.0	50.0	47.2	41.3	33.0	29.6	25.9	20.2	16.8	
60.5	42.8	63.6	59.7	54.3	50.8	48.0	41.9	32.6	27.6	22.8	17.6	15.1	

The serial printer must have 80 columns.

The serial communication format is as follows:

- Speed: 9600 Baud
- Data Bits: 8
- Parity: No
- Stop Bits: 1

To send the value of the measured functions to a printer, the serial communication with the printer must be enabled in BLUETOOTH®/PRINTER wireless communication option of SC420 menu. The symbol  appears in the indicator area.

While this option is enabled, the serial communication or Bluetooth® wireless communication with a computer is not possible.

When the SC420 is turned on, the RS-232 communication is set to the programmed state: Bluetooth® wireless communication, serial communication with printer or OFF.

17.2.3 USB communications

The USB is a digital communication input/output that complies with USB rev. 2.0. and is available on the underside of the SC420.

The USB connector is of the micro-B USB type. To connect it to a computer, use the CN400 cable.

USB communication offers high-speed transfer, ideal for downloading the large quantities of data that the SC420 can store. It can also be used to programme the SC420 and send data in real time.

To download records containing audio files, we recommend directly importing them from the memory card.

17.2.4 Bluetooth® wireless communication

The SC420 is equipped with class 1 internal Bluetooth® wireless communication for communication with a computer.

From the BLUETOOTH® WIRELESS COMMUNICATION option in the SETTINGS menu you can enable or disable this input/output (see 15.3.8).

To use Bluetooth® wireless communication via radio frequency link with a computer, the computer must have a Bluetooth® wireless communication device*, or you can purchase the BT002 Bluetooth® wireless communication device for PC .

Bluetooth® wireless technology is used for measuring acoustic insulation between rooms, as the communication can be established through walls, and also in continuous noise monitoring terminals, as these tend to be situated at a height of 4.0 m, which means data can be downloaded and the terminals programmed from street level, without having to physically access them.

NOTE: To save battery power, disable Bluetooth® wireless communication when it is not needed.

***CESVA** accepts no responsibility for problems caused by using any Bluetooth® wireless communication device other than the *BT002*.

17.3 PC software

The communications software supplied with the *SC420* **CESVA** Lab lets you:

- Download registers stored on the *SC420*.
- Import registers saved on the *SC420* memory card.
- Manage registers (total or selective deletion).

The *SC420* lets you download data as it is being recorded. That is, while data are being recorded, they can be downloaded at the same time. It also offers the possibility of deleting some of the registers stored on the card after they have been downloaded.

For all these functions, you need to choose the type of communication between the *SC420* and the computer. This may be RS-232, USB or wireless Bluetooth®.

In addition, the Cesva Lab Software allows the following actions:

- Numerical and graphical display and reporting of records downloaded from the *SC420*,
- Editing and recalculating the registers downloaded from the *SC420*

Further information on how the software application works is available in its 'help' section.

The following section describes the accessories supplied with the *SC420* and the optional accessories that can be purchased separately.

18.1 Accessories supplied

The accessories supplied with the *SC420* are the following:

MODEL	DESCRIPTION
CESVALab	CESVA <i>Memory Download</i> computer communication software
CN400	MicroUSB-USB PC connection cable
PV009	Windscreen
	MicroSD memory card
	2 units of 1.5 V batteries

18.2 Optional accessories

The optional accessories for the *SC420* are the following:

MODEL	DESCRIPTION
CB006	Class 1 acoustic calibrator
TR040	Tripod (height 1.10 m)
TR050	Tripod (height 1.50 m)
ML043	Transport briefcase (48x37x16 cm)
ML013	Transport briefcase (39x32x12 cm)
ML063	Special outdoors transport briefcase (51x38x15 cm)
AM300	Mains feeder (V= 100/240 V, 50/60 Hz)
FN004	Protective case
TK200	Outdoor kit
CN003	Microphone extension cable (3 m)
CN010	Microphone extension cable (10 m)
CN030	Microphone extension cable (30 m)
CN420	Multi-connector cable

TR001	Tripod adaptor
PR003	Extendible rod (3 m)

NOTE: **CESVA** only guarantees the correct functioning of the device when original **CESVA** accessories are used Any damage caused to the device owing to the use of non-original accessories will not be covered by the warranty.

This section contains the technical specifications of the **CESVA** SC420 sound level meter, which is designed to comply with, among others, with the following standards:

- IEC 61672–1 (2002–05), Class 1, Group Z
- IEC 61260:1995/A1:2001, Class 1

In accordance with standard IEC 61672-1, the class of the SC420 for response to sound waves incident on the microphone in the reference direction in a free field depends on the microphone used.

CLASS	MICROPHONE	PREAMPLIFIER
1	C-130	PA020
1	C140	PA020
1	C240	PA040

When the field correction is set to diffuse field, the SC420 complies with the class indicated above according to standard IEC 61672-1 for response with random incidence in a diffuse field; it also complies with standards ANSI S1.4:83(R2001) and ANSI S1.43:97(R2002).

NOTE: The specifications in bold include (in brackets) the sub-section of Chapter 9.3 of standard IEC 61672-1 concerning information for testing sound level meters.

19.1 REFERENCE CONDITIONS

REFERENCE DIRECTION	Perpendicular to the microphone diaphragm
MICROPHONE REFERENCE POINT (c) C-130, C140 and C240	Central point of the microphone diaphragm
RANGE OF REFERENCE LEVELS (b)	There is only one range of levels and this is the reference range
REFERENCE SOUND PRESSURE LEVEL (a)	94 dB (referred to 20 µPa)
REFERENCE FREQUENCY	1 kHz
REFERENCE TEMPERATURE	23 °C
REFERENCE RELATIVE HUMIDITY	50 %
REFERENCE ATMOSPHERIC PRESSURE	101.325 kPa

19.2 MICROPHONES AND PREAMPLIFIERS

The table below shows the technical features of the microphones and the accessories that attach to them.

19.2.1 Microphone models and their main features

As a class 1 device, the SC420 can be used in conjunction with the following **CESVA** brand microphone models: C-130, C140 and C240.

MICROPHONE	MICROPHONE C-130	MICROPHONE C140	MICROPHONE C240
TYPE, SIZE and FIELD	condenser, ½" and free field		
REFERENCE DIRECTION	Perpendicular to the microphone diaphragm		
POLARISATION	200 V	200 V	0 V
NOMINAL CAPACITANCE	22.5 pF	20.0 pF	20.0 pF
NOMINAL SENSITIVITY in reference conditions	17.5 mV/Pa	43.5 mV/Pa	49.0 mV/Pa
MAXIMUM SPL (j) that the microphone can measure without harming the device	156 dB	150 dB	150 dB
ELECTRICAL CHECKING ADAPTOR (g)	ADM0C130 adaptor	ADM0C130 adaptor	ADM0C130 adaptor
MAXIMUM VOLTAGE APPLICABLE WITH THE ADAPTOR (i)	26 Vpp	26 Vpp	26 Vpp
ADAPTOR FOR ELECTRICAL NOISE TESTS (h)	ADM0C130 adaptor + TP001 clasp	ADM0C130 adaptor + TP001 clasp	ADM0C130 adaptor + TP001 clasp

19.2.2 Sound field correction for periodic tests

To carry out periodic tests, it is recommended to use the B&K Multifunction Acoustic Calibrator Model 4226, the B&K Electrostatic Actuator Model UA035 or the **CESVA** Electrostatic Actuator Model IC150 (d)

SOUND FIELD CORRECTION GENERATED BY B&K MULTIFUNCTION ACOUSTIC CALIBRATOR MODEL 4226 IN A FREE FIELD

MICROPHONE	C-130	C140	C240
FREQUENCY (Hz)	Correction (dB)	Correction (dB)	Correction (dB)
31.5	-0.1	-0.1	-0.1
63	-0.1	0.0	0.0
125	0.0	0.0	0.0
250	0.0	0.0	0.0
500	0.0	0.1	0.1
1000	0.1	0.1	0.1
2000	0.3	0.3	0.2

4000	1.2	1.1	0.9
8000	3.2	3.1	3.0
12500	6.3	6.3	6.2
16000	8.8	7.9	7.6

CORRECTION OF THE RESPONSE OBTAINED WITH THE B&K ELECTROSTATIC ACTUATOR MODEL UA035 IN A FREE FIELD

MICROPHONE		C-130	C140	C240
FREQUENCY (Hz)		Correction	Correction	Correction
Exact base 10 frequency		[dB]	[dB]	[dB]
63	63.0957	0.00	0.00	0.00
80	79.4328	0.00	0.00	0.00
100	100	0.00	0.00	0.00
125	125.893	0.00	0.00	0.00
160	158.489	0.00	0.00	0.00
200	199.526	0.00	0.00	0.00
250	251.189	0.00	0.00	0.00
315	316.228	-0.03	0.01	-0.02
400	398.107	-0.02	0.02	0.00
500	501.187	0.02	0.02	0.00
630	630.957	0.01	0.03	0.01
800	794.328	0.04	0.05	0.03
1000	1000	0.04	0.07	0.06
	1059.25	0.11	0.08	0.07
	1122.02	0.11	0.10	0.07
	1188.50	0.14	0.12	0.09
1250	1258.93	0.15	0.13	0.10
	1333.52	0.13	0.14	0.11
	1412.54	0.17	0.15	0.13
	1496.24	0.20	0.17	0.15
1600	1584.89	0.22	0.20	0.18
	1678.80	0.25	0.22	0.21
	1778.28	0.26	0.25	0.23
	1883.65	0.30	0.28	0.26
2000	1995.26	0.33	0.31	0.30
	2113.49	0.36	0.35	0.33
	2238.72	0.43	0.39	0.37
	2371.37	0.47	0.44	0.42

2500	2511.89	0.52	0.49	0.47
	2660.73	0.56	0.54	0.52
	2818.38	0.63	0.60	0.58
	2985.38	0.70	0.67	0.65
3150	3162.28	0.78	0.74	0.71
	3349.65	0.86	0.81	0.79
	3548.13	0.96	0.89	0.87
	3758.37	1.06	0.99	0.97
4000	3981.07	1.19	1.09	1.07
	4216.97	1.32	1.21	1.20
	4466.84	1.45	1.35	1.34
	4731.51	1.61	1.48	1.47
5000	5011.87	1.78	1.65	1.64
	5308.84	1.97	1.81	1.81
	5623.41	2.15	1.97	1.97
	5956.62	2.38	2.16	2.16
6300	6309.57	2.61	2.37	2.40
	6683.44	2.86	2.60	2.64
	7079.46	3.09	2.85	2.88
	7498.94	3.35	3.12	3.14
8000	7943.28	3.74	3.37	3.38
	8413.95	4.04	3.61	3.59
	8912.51	4.34	3.90	3.83
	9440.61	4.62	4.23	4.17
10000	10000	5.00	4.58	4.57
	10592.5	5.25	5.00	5.09
	11220.2	5.72	5.65	5.71
	11885.0	6.16	6.18	6.26
12500	12589.3	6.51	6.67	6.85
	13335.2	6.90	7.02	7.22
	14125.4	7.40	7.44	7.58
	14962.4	7.77	7.88	7.99
16000	15848.9	8.32	8.11	8.28
	16788.0	8.52	8.40	8.64
	17783.8	8.86	8.73	8.91
	18836.5	9.23	8.91	8.98
20000	19952.6	9.41	9.10	9.16

CORRECTION OF THE RESPONSE OBTAINED WITH THE **CESVA** ELECTROSTATIC ACTUATOR IC150 IN A FREE FIELD

MICROPHONE		C-130	C140	C240
FREQUENCY (Hz)		Correction	Correction	Correction
Exact base 10 freq.		[dB]	[dB]	[dB]
63	63.0957	0.00	0.00	0.00
80	79.4328	0.00	0.00	0.00
100	100	0.00	0.00	0.00
125	125.893	0.00	0.00	0.00
160	158.489	0.00	0.00	0.00
200	199.526	0.00	0.00	0.00
250	251.189	0.00	0.00	0.00
315	316.228	-0.03	0.01	-0.01
400	398.107	-0.03	0.02	0.00
500	501.187	0.02	0.02	0.01
630	630.957	0.01	0.03	0.02
800	794.328	0.04	0.05	0.02
1000	1000	0.05	0.07	0.06
	1059.25	0.11	0.07	0.06
	1122.02	0.12	0.09	0.07
	1188.50	0.14	0.11	0.09
1250	1258.93	0.16	0.12	0.09
	1333.52	0.15	0.13	0.11
	1412.54	0.19	0.14	0.13
	1496.24	0.22	0.16	0.14
1600	1584.89	0.24	0.18	0.17
	1678.80	0.27	0.20	0.19
	1778.28	0.28	0.23	0.22
	1883.65	0.31	0.27	0.24
2000	1995.26	0.34	0.30	0.29
	2113.49	0.38	0.33	0.32
	2238.72	0.44	0.38	0.35
	2371.37	0.49	0.42	0.40
2500	2511.89	0.54	0.48	0.46
	2660.73	0.60	0.52	0.50
	2818.38	0.66	0.58	0.56
	2985.38	0.74	0.64	0.62

3150	3162.28	0.83	0.71	0.68
	3349.65	0.92	0.79	0.76
	3548.13	1.02	0.85	0.83
	3758.37	1.13	0.95	0.94
4000	3981.07	1.25	1.04	1.04
	4216.97	1.38	1.17	1.16
	4466.84	1.53	1.30	1.29
	4731.51	1.71	1.43	1.42
5000	5011.87	1.89	1.60	1.59
	5308.84	2.07	1.77	1.76
	5623.41	2.27	1.95	1.93
	5956.62	2.50	2.17	2.15
6300	6309.57	2.75	2.43	2.44
	6683.44	3.02	2.70	2.70
	7079.46	3.25	2.96	2.98
	7498.94	3.55	3.23	3.24
8000	7943.28	3.90	3.48	3.48
	8413.95	4.22	3.70	3.68
	8912.51	4.54	3.90	3.88
	9440.61	4.86	4.16	4.13
10000	10000	5.27	4.41	4.43
	10592.5	5.53	4.65	4.77
	11220.2	6.01	5.09	5.23
	11885.0	6.43	5.59	5.71
12500	12589.3	6.77	6.15	6.23
	13335.2	7.18	6.67	6.74
	14125.4	7.72	7.19	7.24
	14962.4	8.17	7.85	7.89
16000	15848.9	8.77	8.29	8.42
	16788.0	8.97	8.60	8.73
	17783.8	9.22	8.80	8.96
	18836.5	9.55	8.83	8.98
20000	19952.6	9.86	9.00	9.07

19.2.3 Frequency response

RESPONSE TO PLANE PROGRESSIVE SOUND WAVES INCIDENT IN THE REFERENCE DIRECTION

Correction for the average frequency microphone response for plane progressive sound waves incident in the reference direction.

MICROPHONE		C-130	C140	C240	
FREQUENCY (Hz)		Correction	Correction	Correction	Uncertainty
Exact base 10 freq.		[dB]	[dB]	[dB]	[dB]
63	63.0957	0.00	0.00	0.00	0.06
80	79.4328	0.00	0.00	0.00	0.06
100	100	0.00	0.00	0.00	0.06
125	125.893	0.00	0.00	0.00	0.06
160	158.489	0.00	0.00	0.00	0.06
200	199.526	0.00	0.00	0.00	0.06
250	251.189	0.00	0.00	0.00	0.06
315	316.228	-0.05	0.00	-0.02	0.06
400	398.107	-0.07	0.00	-0.02	0.06
500	501.187	-0.05	0.00	-0.02	0.06
630	630.957	-0.08	0.00	-0.02	0.06
800	794.328	-0.08	0.00	-0.03	0.06
1000	1000	-0.09	-0.01	-0.03	0.06
	1059.25	-0.07	-0.01	-0.03	0.06
	1122.02	-0.08	0.00	-0.03	0.06
	1188.50	-0.07	0.01	-0.03	0.06
1250	1258.93	-0.08	0.00	-0.03	0.06
	1333.52	-0.10	0.00	-0.03	0.06
	1412.54	-0.09	0.00	-0.03	0.06
	1496.24	-0.08	0.01	-0.03	0.06
1600	1584.89	-0.08	0.01	-0.02	0.06
	1678.80	-0.08	0.01	-0.02	0.06
	1778.28	-0.10	0.01	-0.02	0.06
	1883.65	-0.10	0.02	-0.02	0.06
2000	1995.26	-0.10	0.02	-0.01	0.06
	2113.49	-0.10	0.02	-0.01	0.06
	2238.72	-0.09	0.03	-0.02	0.06
	2371.37	-0.08	0.03	-0.02	0.06

2500	2511.89	-0.08	0.04	-0.02	0.06
	2660.73	-0.08	0.03	-0.03	0.06
	2818.38	-0.09	0.03	-0.02	0.06
	2985.38	-0.08	0.03	-0.03	0.06
3150	3162.28	-0.07	0.02	-0.04	0.06
	3349.65	-0.06	0.03	-0.04	0.06
	3548.13	-0.05	0.01	-0.06	0.06
	3758.37	-0.05	0.01	-0.05	0.06
4000	3981.07	-0.03	-0.01	-0.07	0.06
	4216.97	-0.02	-0.01	-0.06	0.06
	4466.84	-0.01	-0.01	-0.06	0.06
	4731.51	0.00	-0.03	-0.07	0.06
5000	5011.87	0.01	-0.02	-0.05	0.06
	5308.84	0.01	-0.05	-0.06	0.06
	5623.41	0.02	-0.09	-0.08	0.06
	5956.62	0.03	-0.12	-0.09	0.06
6300	6309.57	0.04	-0.15	-0.08	0.06
	6683.44	0.05	-0.18	-0.07	0.06
	7079.46	0.01	-0.22	-0.07	0.06
	7498.94	0.03	-0.26	-0.08	0.06
8000	7943.28	0.08	-0.35	-0.13	0.06
	8413.95	0.07	-0.49	-0.24	0.06
	8912.51	0.05	-0.66	-0.37	0.06
	9440.61	0.00	-0.79	-0.46	0.06
10000	10000	0.02	-0.94	-0.49	0.06
	10592.5	-0.11	-1.10	-0.49	0.08
	11220.2	-0.04	-1.08	-0.36	0.08
	11885.0	-0.03	-0.99	-0.21	0.08
12500	12589.3	-0.14	-0.87	-0.05	0.08
	13335.2	-0.19	-0.86	0.03	0.08
	14125.4	-0.12	-0.86	0.09	0.08
	14962.4	-0.22	-0.82	0.23	0.08
16000	15848.9	-0.12	-0.88	0.23	0.08

Correction for the average effects of the reflections of the sound level meter case and the diffraction around the microphone for plane progressive sound waves incident in the reference direction

FREQUENCY (Hz)		Correction	Uncertainty
	Exact base 10 freq.	[dB]	[dB]
63	63.0957	0.00	0.11
80	79.4328	0.00	0.11
100	100	0.00	0.11
125	125.893	0.00	0.11
160	158.489	0.00	0.11
200	199.526	0.00	0.11
250	251.189	0.00	0.11
315	316.228	-0.05	0.11
400	398.107	0.02	0.11
500	501.187	0.03	0.11
630	630.957	0.04	0.11
800	794.328	-0.07	0.11
1000	1000	-0.09	0.11
	1059.25	-0.13	0.14
	1122.02	-0.12	0.14
	1188.50	-0.16	0.14
1250	1258.93	-0.19	0.14
	1333.52	-0.15	0.14
	1412.54	-0.11	0.14
	1496.24	0.00	0.14
1600	1584.89	0.04	0.14
	1678.80	-0.07	0.14
	1778.28	0.02	0.14
	1883.65	-0.08	0.14
2000	1995.26	0.03	0.14
	2113.49	0.09	0.14
	2238.72	-0.09	0.14
	2371.37	-0.14	0.14
2500	2511.89	-0.11	0.14
	2660.73	-0.03	0.14
	2818.38	0.00	0.14
	2985.38	-0.15	0.14
3150	3162.28	-0.07	0.14
	3349.65	0.03	0.14

	3548.13	-0.13	0.14
	3758.37	-0.02	0.14
4000	3981.07	0.00	0.14
	4216.97	-0.13	0.14
	4466.84	-0.14	0.14
	4731.51	-0.25	0.14
5000	5011.87	-0.08	0.14
	5308.84	-0.11	0.14
	5623.41	0.02	0.14
	5956.62	-0.09	0.14
6300	6309.57	-0.14	0.14
	6683.44	-0.10	0.14
	7079.46	-0.26	0.14
	7498.94	-0.11	0.14
8000	7943.28	-0.16	0.14
	8413.95	-0.04	0.14
	8912.51	0.02	0.14
	9440.61	-0.12	0.14
10000	10000	-0.12	0.14
	10592.5	-0.02	0.42
	11220.2	-0.02	0.42
	11885.0	0.01	0.42
12500	12589.3	-0.19	0.42
	13335.2	-0.03	0.42
	14125.4	0.02	0.42
	14962.4	-0.21	0.62
16000	15848.9	-0.09	0.62

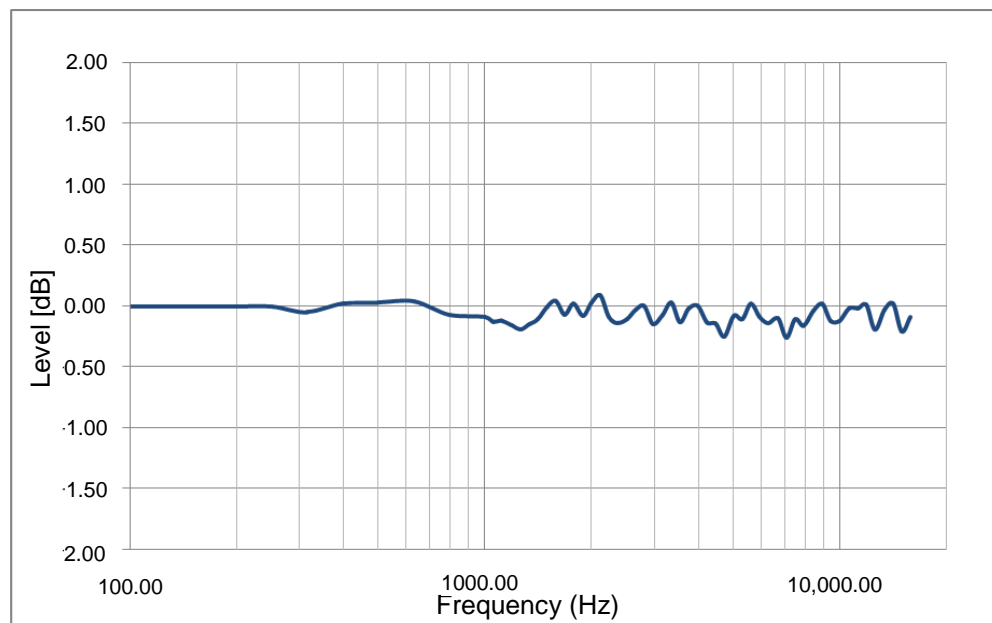

Correction for the average effects of the PV009 windscreen on the sound level meter frequency response in the absence of wind.

FREQUENCY (Hz)		PV009 WINDSCREEN	
	Exact base 10 freq.	Correction (dB)	Uncertainty [dB]
1000	1000	0.35	0.00
1250	1258.93	0.45	0.11
1600	1584.89	0.61	0.11
2000	1995.26	0.57	0.11
2500	2511.89	0.35	0.11
3150	3162.28	0.12	0.11
4000	3981.07	0.30	0.11
5000	5011.87	0.24	0.11
6300	6309.57	0.09	0.11
8000	7943.28	-0.05	0.11
10000	10000	-0.23	0.11
12500	12589.3	-0.14	0.57
16000	15848.9	-0.54	0.85

The discrepancies between the measured frequency response effects of the different microphones, reflection, diffraction and the windscreen, extended with the uncertainty, do not exceed two thirds of the tolerance limits specified in section 19.3.7.

RESPONSE WITH RANDOM INCIDENCE IN A DIFFUSE FIELD

Correction for the average frequency response of the SC420 sound level meter, with the sound field correction set to diffuse field, for response with random incidence in a diffuse field.

MICROPHONE		C-130	C140	C240
FREQUENCY (Hz)		Correction	Correction	Correction
Exact base 10 freq.		[dB]	[dB]	[dB]
250	251.189	-0.26	-0.26	-0.23
315	316.228	-0.28	-0.23	-0.24
400	398.107	-0.27	-0.20	-0.21
500	501.187	-0.19	-0.14	-0.16
630	630.957	-0.06	0.02	0.00
800	794.328	-0.02	0.06	0.03
1000	1000	-0.03	0.05	0.03
1250	1258.93	-0.11	-0.03	-0.05
1600	1584.89	-0.19	-0.10	-0.11
2000	1995.26	-0.33	-0.21	-0.23
2500	2511.89	-0.17	-0.05	-0.11
3150	3162.28	-0.29	-0.20	-0.23
4000	3981.07	-0.36	-0.34	-0.38
5000	5011.87	-0.25	-0.28	-0.30
6300	6309.57	-0.13	-0.32	-0.24
8000	7943.28	0.01	-0.42	-0.17
10000	10000	0.11	-0.85	-0.59
12500	12589.3	-0.08	-0.81	0.08
16000	15848.9	-0.11	-0.87	0.28
20000	19952.6	-0.66	-1.87	-0.54

19.2.4 Directional response

Sound level meter directional response to plane progressive waves with angles of incidence 30°, 90° and 150°, including the reference direction.

**Maximum variation in sensitivity at 30°, 90° and 150° in relation to the reference direction extended with the expanded measurement uncertainty
Vertical and Horizontal Planes SC420**

FREQUENCY [kHz]	Variation at 30° [dB]		Variation at 90° [dB]		Variation at 150° [dB]	
	Vertical	Horizontal	Vertical	Horizontal	Vertical	Horizontal
0.25 to 1	0.5	0.4	1.1	0.9	1.2	1.0
>1 to 2	0.5	0.4	1.2	1.0	1.5	1.3
>2 to 4	1.0	0.8	2.1	1.9	2.8	2.4
>4 to 8	1.9	1.7	4.7	4.2	5.7	5.9
>8 to 12.5	2.6	2.4	7.8	7.4	9.8	9.9

VERTICAL PLANE DIRECTIVITY DIAGRAMS

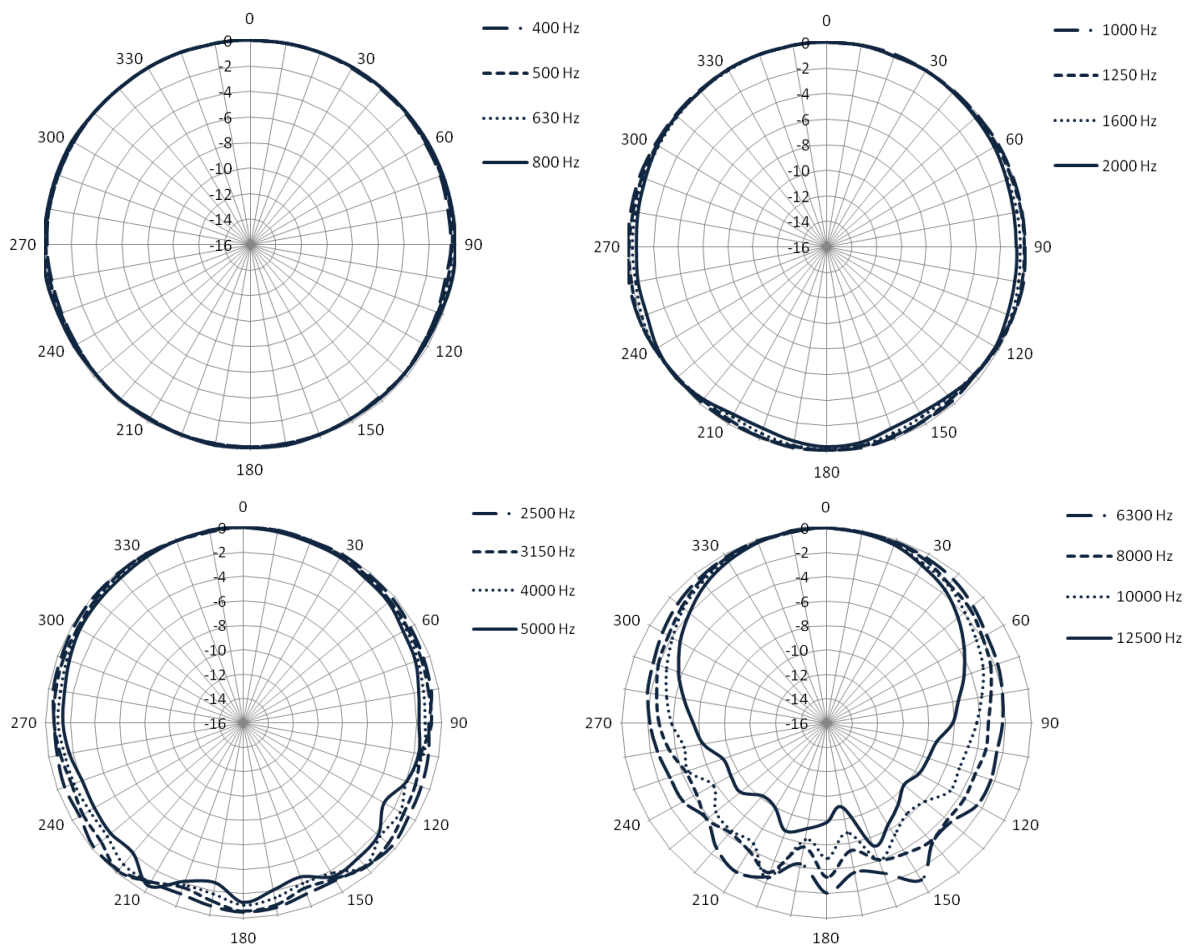

HORIZONTAL PLANE DIRECTIVITY DIAGRAMS

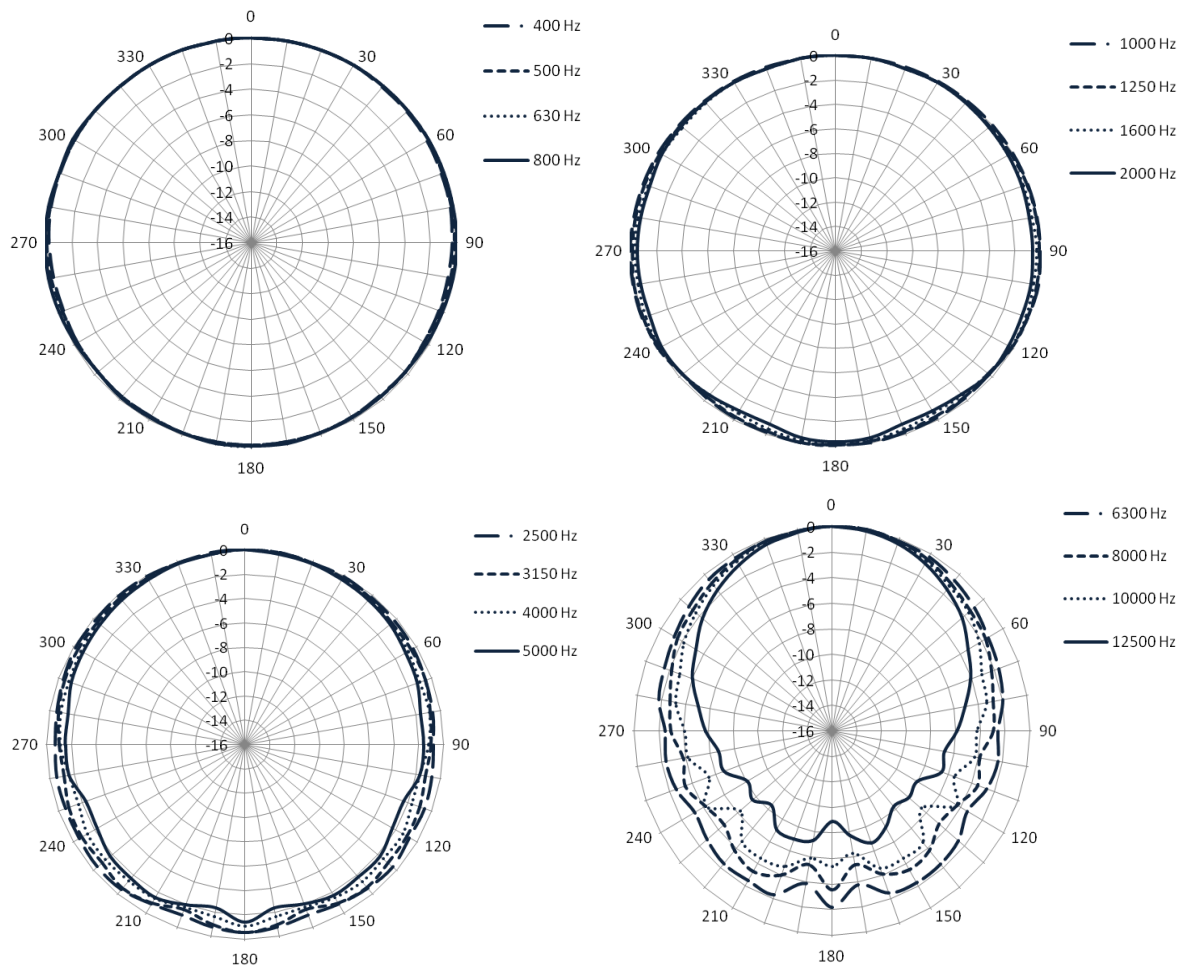

19.2.5 Effect of the optional accessories on the microphone

The *SC420* complies with the specifications of this standard for the same operating class when the following accessories are installed: the *TK200* outdoor kit, the extension cables and the *TRO01* tripod support.

OUTDOOR KIT

Correction owing to the average effect of the outdoor kit on the microphone frequency response.

FREQUENCY (Hz)		OUTDOOR KIT
Exact base 10 freq.		Correction (dB)
1000	1000	0.10
1250	1258.93	0.10
1600	1584.89	0.40
2000	1995.26	0.70
2500	2511.89	1.20

3150	3162.28	1.40
4000	3981.07	1.30
5000	5011.87	0.60
6300	6309.57	0.30
8000	7943.28	1.40
10000	10000	-0.70
12500	12589.3	-4.00
16000	15848.9	-6.20

With the protective cover and the *TK200* Outdoor Kit, the *SC420* has an IP65 level of protection.

CABLES

The cables do not have any effect inside the measuring frequency band. A recalibration is not necessary when using the extension cables.

TRIPOD ADAPTOR

The influence of the *TR001* tripod adaptor on the frequency response and directivity is negligible.

19.2.6 Preamplifier connector

Connect the *PA020* and *PA040* to the *SC420* using LEMO-type connectors: with a female LEMO connector on the sound level meter and a male LEMO connector on the preamplifier. The pin-out of the connector appears as follows (exterior view):

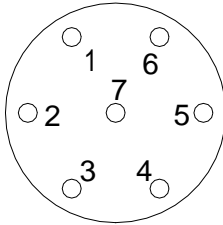
sound level meter FEMALE CONNECTOR		1	No connection
		2	Signal ground
		3	200 V polarisation voltage
		4	Signal
		5	+ 28 V
		6	+ 28 V
		7	Power ground

19.3 MEASUREMENT

19.3.1 Warm-up time

The warm-up time is 15 seconds.

19.3.2 Measurement range

Measurement range at 1 kHz for the SC420 sound level meter with the C-130+PA020, C140+PA020 and C240+PA040 microphone and preamplifier sets:

FUNCTIONS: L_F , L_S , L_I , L_t and L_T : including L_{AeqT}

Microphone and preamplifier	Weighting A [dB]	Weighting C [dB]	Weighting Z [dB]
C-130+PA020	24.8 to 137.0	26.3 to 137.0	31.0 to 137.0
C140+PA020	23.4 to 137.0	23.4 to 137.0	27.2 to 137.0
C240+PA040	23.4 to 137.0	23.8 to 137.0	27.8 to 137.0

FUNCTION: L_{Cpeak} :

Microphone and preamplifier	Weighting C [dB]
C-130+PA020, C140+PA020 and C240+PA040	55.0 to 140.1

19.3.3 Linearity range

The starting point for linearity testing is 94.0 dB (f)

FUNCTIONS: L_F , L_S , L_I , L_t and L_T : including L_{AeqT}

Tables of the nominal sound levels with weighting A in the upper and lower limits of the linear functioning ranges in each level range (e).

Typical linearity range for the SC420 sound level meter with the C130 microphone and the PA020 preamplifier:

Frequency (Hz)	Weighting A [dB]	Weighting C [dB]	Weighting Z [dB]
31.5	24.8 to 97.5	26.3 to 133.9	31.0 to 136.8
1000	24.8 to 137.0	26.3 to 137.0	31.0 to 137.0
4000	24.8 to 138.2	26.3 to 136.5	31.0 to 137.1
8000	24.8 to 136.1	26.3 to 134.1	31.0 to 137.2
12500	24.8 to 130.9	26.3 to 128.9	31.0 to 136.9

Typical linearity range for the SC420 sound level meter with the C140 microphone and the PA020 preamplifier:

Frequency (Hz)	Weighting A [dB]	Weighting C [dB]	Weighting Z [dB]
31.5	23.4 to 97.5	23.4 to 133.9	27.2 to 136.8
1000	23.4 to 137.0	23.4 to 137.0	27.2 to 137.0
4000	23.4 to 138.2	23.4 to 136.5	27.2 to 137.1
8000	23.4 to 136.1	23.4 to 134.1	27.2 to 137.2
12500	23.4 to 130.9	23.4 to 128.9	27.2 to 136.9

Typical linearity range for the SC420 sound level meter with the C240 microphone and the PA040 preamplifier:

Frequency (Hz)	Weighting A [dB]	Weighting C [dB]	Weighting Z [dB]
31.5	23.4 to 97.5	23.8 to 133.9	27.8 to 136.8
1000	23.4 to 137.0	23.8 to 137.0	27.8 to 137.0
4000	23.4 to 138.2	23.8 to 136.5	27.8 to 137.1
8000	23.4 to 136.1	23.8 to 134.1	27.8 to 137.2
12500	23.4 to 130.9	23.8 to 128.9	27.8 to 136.9

19.3.4 Noise

Highest expected intrinsic noise level produced when the sound level meter is placed in a lower level acoustic field, and when a specified electrical input device is installed in place of the microphone and stops suddenly (h).

Intrinsic noise of the SC420 sound level meter with the C-130 microphone and the PA020 preamplifier:

		Weighting A [dB]	Weighting C [dB]	Weighting Z [dB]
ELECTRICAL NOISE	TYPICAL	11.5	13.4	18.9
(replacing the microphone with its corresponding adapter and cap)	MAXIMUM	12.1	14.3	19.9
TOTAL NOISE at 20 °C	TYPICAL	17.3	18.8	23.5
(electrical + thermal microphone noise):	MAXIMUM	20.4	21.5	26.2

Intrinsic noise of the SC420 sound level meter with the C140 microphone and the PA020 preamplifier:

		Weighting A [dB]	Weighting C [dB]	Weighting Z [dB]
ELECTRICAL NOISE	TYPICAL	7.7	8.0	14.2
(replacing the microphone with its corresponding adapter and cap)	MAXIMUM	8.2	8.5	14.7
TOTAL NOISE at 20 °C	TYPICAL	15.9	15.9	19.7
(electrical + thermal microphone noise):	MAXIMUM	16.2	16.3	22.1

Intrinsic noise of the SC420 sound level meter with the C240 microphone and the PA040 preamplifier:

		Weighting A [dB]	Weighting C [dB]	Weighting Z [dB]
ELECTRICAL NOISE	TYPICAL	5.2	6.3	12.8
(replacing the microphone with its corresponding adapter and cap)	MAXIMUM	5.9	7.0	13.3
TOTAL NOISE at 20 °C	TYPICAL	15.9	16.3	20.3
(electrical + thermal microphone noise):	MAXIMUM	17.3	18.1	26.5

NOTE: For electrical noise tests, the adaptor and cap appropriate to each microphone should be used.

NOTE: Intrinsic noise is measured with equivalent levels with integration time greater than 30 seconds.

19.3.5 Information for testing compliance withdrawn standards IEC 60651 and IEC 60804

PRIMARY INDICATOR RANGE (Functions L_F, L_S, L_I, L_E, L_t and L_T)

Microphone and preamplifier	Weighting A [dB]	Weighting C [dB]	Weighting Z [dB]
C-130+PA020	30.0 to 120.0	32.0 to 120.0	38.0 to 120.0
C140+PA020	30.0 to 120.0	32.0 to 120.0	38.0 to 120.0
C240+PA040	28.2 to 120.0	28.6 to 120.0	34.0 to 120.0

AVERAGING (Functions L_T, L_t and L_E)

Linearity range	110 dB
Pulse range	65 dB
Response time to a steady input signal	2 s

DETECTOR (Functions L_F, L_S and L_I)

Function	Pulse duration [dB]	Maximum error (dB)
LF	200	± 1.0
LS	500	± 1.0
LI	20	± 1.5
	5	± 2.0
	2	± 2.0

Maximum error for signals with crest factor ≤ 3:	± 0.5 dB
Maximum error for signals with crest factor ≤ 5:	± 1.0 dB
Maximum error for signals with crest factor ≤ 10:	± 1.5 dB
Maximum overshoot:	LF: 1.1 dB LS: 1.6 dB
Maximum error of level linearity (31.5 to 12,500 Hz):	± 0.7 dB
Maximum error of differential level linearity (31.5 to 12,500 Hz):	± 0.2 dB
LI function peak detector:	Decay rate: 2.9 dB/s ± 0.5 dB/s Onset time constant: < 3.5 ms

PEAK DETECTOR L_{peak} function

Onset time	< 75 μs
------------	---------

19.3.6 Time and clock features

TIME

The screen refresh time is 1s.

When a measurement starts, the value of the functions that depend on the integration time (T) will appear when the time (T) is finished. This value will be updated every second but the changes on the display will not show until the time (T) is finished.

The clean-up of the maintenance device for conducting measurements of the maximum and minimum time weighted sound level and the peak sound level is automatic and is carried out at the end of each time base period: 125 ms, 1s, T or t; thus, its functioning is intrinsic to the definition of the functions themselves.

The minimum integration time is 125 ms; the programmable integration time (T) can take values from 1 second to 99 hours (1 to 99 seconds, minutes or hours).

When measuring decay curves for reverberation time evaluation, integration times of 10 ms are used. For FFT analysis, the maximum integration time is 1 minute.

CLOCK

The clock has a lower deflection than 10 seconds over a period of 24 hours.

19.3.7 Frequency weighting

The following table lists the frequency weightings available for each function

FUNCTION	WEIGHTING
L _{peak}	A, C or Z
LF	A, C or Z
LS	A, C or Z
LI	A, C or Z
LE	A, C or Z
LT	A, C or Z
L _t	A, C or Z
Ln (percentiles)	A

The following table shows the A, C and Z frequency weightings and tolerance for class 1.

FREQUENCY [Hz]	WEIGHTING A [dB]	WEIGHTING C [dB]	WEIGHTING Z [dB]	TOLERANCE
				CLASS 1 [dB]
10	-70.4	-14.3	0.0	+3.5; -∞
12.5	-63.4	-11.2	0.0	+3.0; -∞
16	-56.7	-8.5	0.0	+2.5; -4.5
20	-50.5	-6.2	0.0	±2.5
25	-44.7	-4.4	0.0	+2.5; -2.0
31.5	-39.4	-3.0	0.0	±2.0
40	-34.6	-2.0	0.0	±1.5
50	-30.2	-1.3	0.0	±1.5
63	-26.2	-0.8	0.0	±1.5
80	-22.5	-0.5	0.0	±1.5
100	-19.1	-0.3	0.0	±1.5
125	-16.1	-0.2	0.0	±1.5
160	-13.4	-0.1	0.0	±1.5
200	-10.9	0.0	0.0	±1.5
250	-8.6	0.0	0.0	±1.4
315	-6.6	0.0	0.0	±1.4
400	-4.8	0.0	0.0	±1.4
500	-3.2	0.0	0.0	±1.4
630	-1.9	0.0	0.0	±1.4
800	-0.8	0.0	0.0	±1.4
1000	0	0	0	±1.1
1250	+0.6	0.0	0.0	±1.4
1600	+1.0	-0.1	0.0	±1.6
2000	+1.2	-0.2	0.0	±1.6
2500	+1.3	-0.3	0.0	±1.6
3150	+1.2	-0.5	0.0	±1.6
4000	+1.0	-0.8	0.0	±1.6
5000	+0.5	-1.3	0.0	±2.1
6300	-0.1	-2.0	0.0	+2.1; -2.6
8000	-1.1	-3.0	0.0	+2.1; -3.1
10000	-2.5	-4.4	0.0	+2.6; -3.6
12500	-4.3	-6.2	0.0	+3.0; -6.0
16000	-6.6	-8.5	0.0	+3.5; -17.0
20000	-9.3	-11.2	0.0	+4.0; -∞

19.4 CALIBRATION

Please use the **CESVA** CB006 acoustic calibrator and refer to sub-section 10.1.

19.5 OCTAVE AND THIRD OCTAVE BAND FILTERS

The SC420 is equipped with class 1 octave and third octave band filters that comply with IEC 61260:1995/A1:2001

19.5.1 Octave and third octave band filters

FREQUENCY EVALUATION SYSTEM	Base 10
REFERENCE ATTENUATION	0 dB
LINEARITY OPERATING RANGE	Same as the measurement range
ANALYTICAL FILTER DESIGN METHOD	Optimised Z-transform for Butterworth analogue filters
SAMPLING FREQUENCY:	
Octave band filters	48 kHz
Third octave band filters	Decimation from 48 kHz
REAL TIME OPERATING FREQUENCY RANGE:	
Octave band filters	Central frequencies 16 to 16000 Hz
Third octave band filters	10 to 20000 Hz

OCTAVE BAND FILTERS		THIRD OCTAVE BAND FILTERS	
NOMINAL CENTRAL FREQUENCY [Hz]	EXACT BASE 10 FREQUENCY [Hz]	NOMINAL CENTRAL FREQUENCY [Hz]	EXACT BASE 10 FREQUENCY [Hz]
		10	10.000
		12.5	12.589
16	15.849	16	15.849
		20	19.953
		25	25.119
31.5	31.623	31.5	31.623
		40	39.811
		50	50.119
63	63.096	63	63.096
		80	79.433
		100	100.00
125	125.89	125	125.89
		160	158.49
		200	199.53
250	251.19	250	251.19
		315	316.23
		400	398.11
500	501.19	500	501.19
		630	630.96

		800	794.33
1000	1000	1000	1000.0
		1250	1258.9
2000	1995.30	1600	1584.9
		2000	1995.3
		2500	2511.9
4000	3981.10	3150	3162.3
		4000	3981.1
		5000	5011.9
8000	7943.30	6300	6309.6
		8000	7943.3
		10000	10000
16000	15849	12500	12589
		16000	15849
		20000	19953

19.5.2 Measurement range (octave band spectrum analyser)

Measurement range (with linearity error lower than 0.4 dB):

MICROPHONE	C-130	C140	C240
PREAMPLIFIER	PA020	PA020	PA040
FREQUENCY (Hz)	Margin [dB]	Margin [dB]	Margin [dB]
16	26.1 to 137	18.8 to 137	19.7 to 137
31.5	23.3 to 137	15.8 to 137	15.8 to 137
63	20.3 to 137	10.0 to 137	13.6 to 137
125	17.7 to 137	10.0 to 137	10.0 to 137
250	16.1 to 137	10.0 to 137	10.0 to 137
500	15.7 to 137	10.0 to 137	10.0 to 137
1000	17.0 to 137	14.0 to 137	14.0 to 137
2000	19.4 to 137	18.0 to 137	17.0 to 137
4000	21.4 to 137	20.0 to 137	20.3 to 137
8000	22.3 to 137	21.0 to 137	21.6 to 137
16000	22.3 to 137	21.0 to 137	21.0 to 137

The noise (electrical + thermal microphone noise) is, as a minimum, 10 dB lower than the lower limit of the measurement range.

19.5.3 Measurement range (third octave spectrum analyser)

Measurement range (with linearity error lower than 0.4 dB):

MICROPHONE	C-130	C140	C240
PREAMPLIFIER	PA020	PA020	PA040
FREQUENCY (Hz)	Margin [dB]	Margin [dB]	Margin [dB]
10	22.5 to 137	15.9 to 137	16.9 to 137
12.5	21.6 to 137	13.6 to 137	15.6 to 137
16	20.8 to 137	10.0 to 137	14.1 to 137
20	19.8 to 137	10.0 to 137	12.7 to 137
25	18.8 to 137	10.0 to 137	10.1 to 137
31.5	17.7 to 137	10.0 to 137	10.0 to 137
40	16.7 to 137	10.0 to 137	10.0 to 137
50	15.7 to 137	10.0 to 137	10.0 to 137
63	14.6 to 137	10.0 to 137	10.0 to 137
80	13.7 to 137	10.0 to 137	10.0 to 137
100	12.3 to 137	10.0 to 137	10.0 to 137
125	11.7 to 137	10.0 to 137	10.0 to 137
160	10.2 to 137	10.0 to 137	10.0 to 137
200	10.0 to 137	10.0 to 137	10.0 to 137
250	10.0 to 137	10.0 to 137	10.0 to 137
315	10.0 to 137	10.0 to 137	10.0 to 137
400	10.0 to 137	10.0 to 137	10.0 to 137
500	10.0 to 137	10.0 to 137	10.0 to 137
630	10.0 to 137	10.0 to 137	10.0 to 137
800	10.0 to 137	10.0 to 137	10.0 to 137
1000	11.7 to 137	10.0 to 137	10.0 to 137
1250	11.7 to 137	10.0 to 137	10.0 to 137
1600	12.9 to 137	10.0 to 137	10.0 to 137
2000	13.9 to 137	10.0 to 137	10.0 to 137
2500	14.7 to 137	10.0 to 137	10.0 to 137
3150	15.6 to 137	10.0 to 137	10.0 to 137
4000	16.4 to 137	14.0 to 137	14.0 to 137
5000	16.9 to 137	14.0 to 137	14.1 to 137
6300	17.3 to 137	14.0 to 137	15.8 to 137
8000	17.7 to 137	14.1 to 137	15.8 to 137
10000	17.7 to 137	14.0 to 137	15.8 to 137
12500	17.3 to 137	14.0 to 137	15.8 to 137
16000	17.3 to 137	14.0 to 137	15.2 to 137
20000	17.3 to 137	15.6 to 137	15.8 to 137

The noise (electrical + thermal microphone noise) is, as a minimum, 10 dB lower than the lower limit of the measurement range.

19.6 REVERBERATION TIME

19.6.1 Measuring the decay curve and impulse response

The decay curve for the **L1** and **L3** modes and the impulse response for the **L1** and **L3** modes are measured from equivalent levels (linear average) with a consecutive integration time of 10 ms over 6 s.

19.6.2 Calculating the decay curve from the impulse response

In the **L1** and **L3** modes, the decay curve is calculated from the impulse response using Schroeder's backward integration method.

19.6.3 Estimating the slope of the decay curve

The estimation of the slope of the decay curve is automatically achieved from the linear regression by least square approximation of itself.

19.6.4 Reverberation time measurement lower limit

The minimum reverberation time is 0.12s and is established by the averaging time of the linear averager.

19.6.5 Quality indicators

Non-linearity parameter ξ , C curvature and B·T product for each frequency band.

19.6.6 Lower limit for reliable results obtained through a filter and a detector

To obtain reliable reverberation time (T) results, the following conditions must be met: $B \cdot T > 16$ and $T > T_{det}$.

AVERAGER DETECTOR REVERBERATION TIME (T_{det})

FREQUENCY [Hz]	T_{det} 1/3 octave band [s]	T_{det} 1/1 octave band [s]
50	0.42	
63	0.33	0.13
80	0.26	
100	0.20	
125	0.17	0.07
160	0.14	
200	0.10	
250	0.08	0.04
315	0.07	

400	0.06	
500	0.04	0.02
630	0.03	
800	0.02	
1000	0.01	0.01
1250	---	
1600	---	---
2000	---	---
2500	---	---
3150	---	---
4000	---	---
5000	---	---
6300	---	---
8000	---	---
10000	---	---

19.7 FFT

TIME WINDOW	Hanning
NO. OF LINES	10000
ANALYSIS RESOLUTION	2 Hz
DYNAMIC MEASUREMENT RANGE	> 80 dB
DETECTOR	Equivalent level
FREQUENCY WEIGHTING	A or Z

19.8 AUDIO RECORDING

FORMAT	WAV file
RESOLUTION:	Analysis quality: 24 bits Listening quality: 16 bits
SAMPLING FREQUENCY:	Analysis quality: 48 kHz Listening quality: 24 kHz
GAIN:	Analysis quality: Optimum and constant throughout the recording Listening quality: Automatic

19.9 ENVIRONMENTAL, ELECTROSTATIC AND RADIO FREQUENCY CRITERIA

19.9.1 Stabilisation time

The stabilisation time after changes in the environmental conditions (I) is 5 minutes.

19.9.2 Environmental criteria

INFLUENCE OF STATIC PRESSURE

OPERATING RANGE	65 to less than 85 kPa	85 to 108 kPa
MAXIMUM ERROR (at 1 kHz and 94 dB or 104 dB)	Class 1 0.9 dB	Class 1 0.4 dB

INFLUENCE OF TEMPERATURE

OPERATING RANGE	Class 1	-10 to +50 °C
MAXIMUM ERROR (-10 to +50°C)	Class 1	0.5 dB
STORAGE WITHOUT BATTERIES		-20 to +60 °C

INFLUENCE OF HUMIDITY

OPERATING RANGE (IN ABSENCE OF CONDENSATION)		25 to 90 %
MAXIMUM ERROR (25% < R.H. < 90% at 40°C and 1 kHz)	Class 1	0.5 dB
STORAGE WITHOUT BATTERIES		< 93 %

19.9.3 Electrostatic criteria

EFFECTS OF STATIC ELECTRICITY DISCHARGES	The equipment shows no degradation or loss of function after being exposed to static electricity discharges. The measured value may be temporarily affected during the application of discharges.
--	---

19.9.4 Criteria for fields at the frequency of the mains supply and radio frequency fields

CLASSIFICATION FOR SUSCEPTIBILITY TO RADIO FREQUENCY FIELDS	Group Z
NORMAL OPERATING MODE	Configure with CN010 microphone extension cable and SC420 in Sound level meter mode, L _{AF} function
REFERENCE ORIENTATION	SC420 in vertical position, with the SC420 main shaft (preamplifier) perpendicular to the field propagation direction with horizontal polarization. With all cables connected, and with the AM300 feeder

RANGE OF ACCESSORIES TESTED IN THE VERIFICATION OF THE ELECTROMAGNETIC COMPATIBILITY REQUIREMENTS	<i>AM300</i> Feeder, <i>CN400</i> USB-microUSB Connecting Cable for communication with PC, <i>CN010</i> 10m Extension Cable, <i>CN420</i> Multi-connector Cable
SOUND LEVEL AT WHICH THE <i>SC420</i> MEETS THE REQUIREMENTS FOR RADIATED ELECTROMAGNETIC FIELD AND FIELD AT THE FREQUENCY OF THE MAINS SUPPLY	74 dBA
INFLUENCE OF MAGNETIC FIELDS	In an 80 A/m magnetic field (1 oersted) at 50 Hz or 60 Hz, the reading variation will be under ± 1 dB
CONFIGURATION FOR THE NORMAL OPERATING MODE AND POSITION THAT PRODUCES THE GREATEST RADIO FREQUENCY EMISSION	Sound level meter mode, LAF function. <i>SC420</i> in vertical position, with the <i>SC420</i> main shaft perpendicular to the field propagation direction with vertical polarisation. With all cables connected, and with the <i>AM300</i> feeder

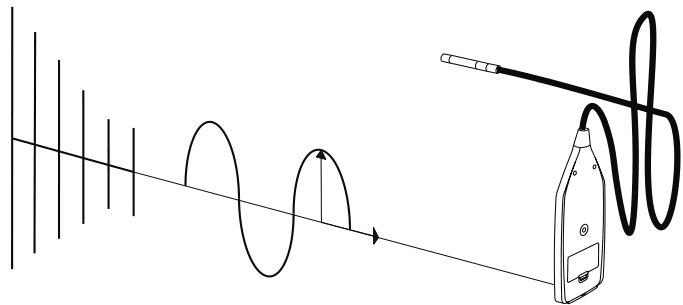

CONFIGURATION FOR THE NORMAL OPERATING MODE AND POSITION THAT PRODUCES THE GREATEST SUSCEPTIBILITY (LEAST IMMUNITY) TO RADIATED FIELDS AND FIELDS CONDUCTED THROUGH THE MAINS SUPPLY	Sound level meter mode, LAF function. <i>SC420</i> in vertical position, with the <i>SC420</i> main shaft perpendicular to the field propagation direction with horizontal polarisation. With all cables connected, and with the <i>AM300</i> feeder
--	--

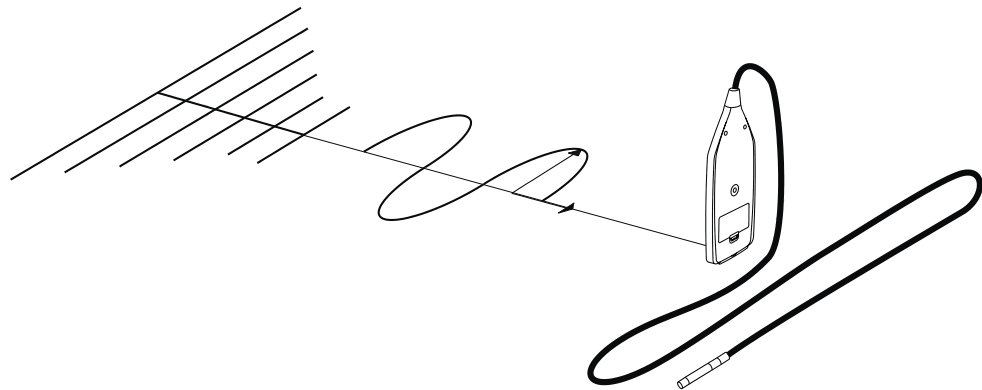

The sound level meter complies with the basic specifications in standard 61672-1 for the required immunity to mains supply frequency and radio frequency fields.

No difference in emission in relation to the normal operating mode is observed with the equipment vertical, with all cables connected and with the *AM300* mains feeder.

19.9.5 Influence of vibrations

FOR FREQUENCIES from 20 to 1000 Hz and 1 m/s ² :	< 75 dBA
---	----------

19.10 INPUTS AND OUTPUTS

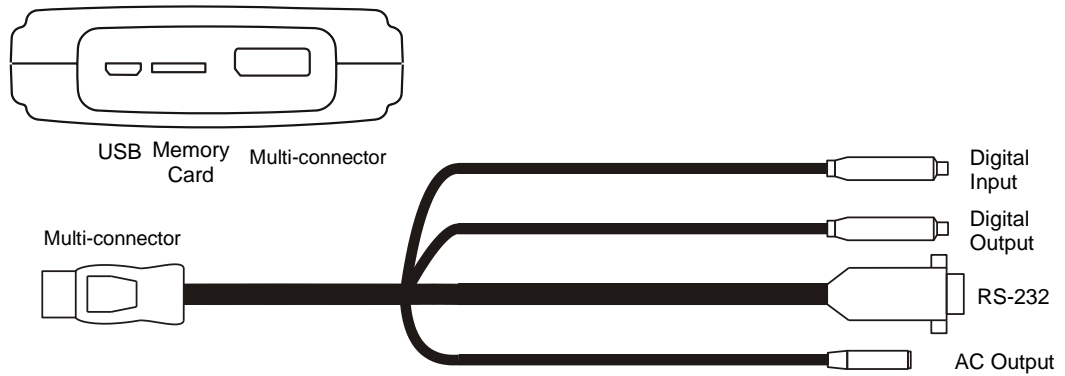

19.10.1 AC Output

TYPE OF OUTPUT	analogical output directly proportional to the preamplifier output
FREQUENCY WEIGHTING:	Without weighting
TYPICAL VOLTAGE AT 94 dB and 1 kHz:	
GAIN: 0 dB	46 mVrms
GAIN: 40 dB	4.6 Vrms
MAXIMUM VOLTAGE:	24 Vpp (typical)
OUTPUT IMPEDANCE:	100 Ω
RECOMMENDED RANGE OF OUTPUT LOAD IMPEDANCE	$R_L \geq 10 \text{ k}\Omega$
GAIN	0 or $40 \pm 0.2 \text{ dB}$
OUTPUT CONNECTOR	female mini jack type
INTERCONNECTION CABLE	Standard audio cable of maximum length 1.5 m and with mono male mini jack connector ($\varnothing 3.5\text{mm}$)

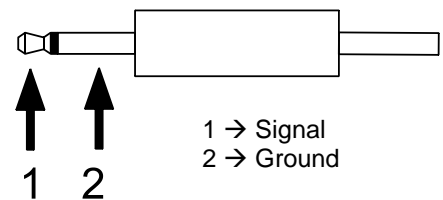

19.10.2 Digital output

TYPE OF OUTPUT	open collector output that takes logical values depending on whether the automatic audio recording threshold is exceeded. If the threshold is exceeded, the signal takes the logical value 0; if it is not exceeded, it maintains the logical value 1.
HIGH LOGICAL VALUE VOLTAGE:	the output voltage of high logical level 1 is fixed through an external resistance of polarisation (pull up)
MAXIMUM VOLTAGE APPLICABLE AT THE OUTPUT:	20 V
MAXIMUM CURRENT APPLICABLE AT THE OUTPUT:	50 mA
OUTPUT IMPEDANCE:	< 10 Ω
OUTPUT CONNECTOR	white female RCA type
INTERCONNECTION CABLE	Standard audio cable of maximum length 1.5 m and with male RCA connector

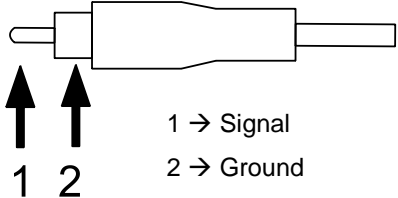

1 → Signal
2 → Ground

19.10.3 Digital input

TYPE OF INPUT	Digital, the open input is INACTIVE (status 1) with the options START AUTOMATIC MEASUREMENT and STOP AUTOMATIC MEASUREMENT activated and configured with the option DIGITAL INPUT. The SC420 waits for the digital input to take the value 0 before starting the recording and the take the value 1 to stop it.	
LOGICAL VALUE VOLTAGES:	INACTIVE (1)	> 1.5 V
	ACTIVE (0)	< 0.5 V
MAXIMUM VOLTAGE APPLICABLE AT THE INPUT:	10 V	
MAXIMUM IMPEDANCE:	< 100 Ω	
INPUT CONNECTOR	red female RCA type	
INTERCONNECTION CABLE	Standard audio cable of maximum length 1.5 m and with male RCA connector	

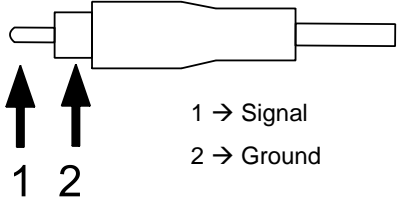

1 → Signal
2 → Ground

19.10.4 MicroSD memory card slot

CARD TYPE	MicroSD with FAT32 or FAT16 format
RECOMMENDED CAPACITY	4 GB
MINIMUM CLASS	4

19.10.5 USB communication

TYPE	Digital: complies with USB rev. 2.0.
FEMALE	USB Micro-B
CONNECTING CABLE	CN400 of 0.5 m in length

19.10.6 RS-232 serial communication

TYPE	Two-way serial digital
TRANSMISSION FORMAT:	
SPEED	115200 bauds
BITS OF DATA	8
PARITY	None
STOP BITS	1
FEMALE	DB-9
CONNECTING CABLE	Standard serial cable of maximum length 1.5 m

19.10.7 Wireless communication

TYPE	Bluetooth® class 1
TRANSMISSION FREQUENCY	2402 to 2480 GHz
RANGE	50 m

19.11 SCREEN

The table below shows the technical characteristics of the SC420 screen:

TYPE	Monochrome LED 128 x 128
SIZE	66.0 x 62.5 mm
RESOLUTION IN THE PRESENTATION OF NOISE LEVELS	0.1 dB

19.12 POWER

19.12.1 Batteries

TYPE	Two AA sized (LR6) 1.5 V alkaline batteries
TYPICAL BATTERY LIFE WITH CONTINUOUS USE: <i>Having the screen light on can reduce the typical battery life value by 50%.</i>	8 hours 45 minutes

19.12.2 External Supply

VOLTAGE INPUT RANGE (j)	4.25 to 5.25 V DC
MINIMUM CURRENT	250 mA
To run the SC420 from a mains supply, is recommended to use the AM300 mains feeder and the CN400 cable	
CESVA accepts no responsibility for the use of feeders other than the recommended one.	
AM300 FEEDER:	
SUPPLY VOLTAGE	100 to 240 VAC
SUPPLY FREQUENCY	50 – 60 Hz

19.13 DIMENSIONS AND WEIGHT

DIMENSIONS	292 x 85 x 25 mm
WEIGHT	with batteries 330 g
	without batteries 280 g

19.14 STANDARDS

19.14.1 Standards

The SC420 complies with the following national and international standards:

IEC 61672-1:02 class 1, EN 61672-1:03 class 1.
IEC 61260:95 (A1:01) class 1, EN 61260:95 (A1:01) class 1
IEC 60804:00 type 1, EN 60804:00 type 1
IEC 60651:01 class 1, EN 60651:94 (A1:94) (A2:01) class 1
ANSI S1.4:83/A: 85 type 1, ANSI S1.43:97 type 1, ANSI S1.11:04 class 1
DIN 45657:2005 in reference to the Taktmaximalpegel function
CE Mark. Complies with 73/23/EEC and EMC 89/336/EEC low-tension regulations, the latter amended by 93/68/EEC.



19.14.2 Standards of measurement and calculation

Using the SC420, measurements and calculations can be performed in accordance with the following national and international standards:

ISO 3382-1 Measurement of the reverberation time in performance spaces

ISO 3382-2 Measurement of the reverberation time in ordinary rooms

ISO 354 Measurement of the absorption coefficient in a reverberation room

ISO 140 Measurement of sound insulation in buildings and of building elements

DIRECTIVE 2003/10/EC OF THE EUROPEAN PARLIAMENT AND THE COUNCIL, of 6 February 2003, on the minimum health and safety requirements concerning the exposure of workers to risks arising from physical agents (noise)

ISO 9612:2009 Determination of exposure to noise in the workplace

19.14.3 Certificates

Type approval Certificate for Spain

19.14.4 Notes

If your SC420 ceases to comply with any of these specifications, please consult your closest official **CESVA** dealer for checking, adjustment or repair.

Below are the precautions and warnings to bear in mind regarding the SC420:

- Only attach or detach the microphone using your hands, never use tools. Never do this when the SC420 is operating. If a 200 V polarised microphone is used, and the sound level meter is switched on, there will be 200 volts at the central preamplifier contact. This is not dangerous, though it might cause the microphone to be dropped.
- Never dismantle the microphone, as this may cause permanent damage.
- Keep the microphone dust free and away from sharp-pointed objects.
- Avoid excessive humidity and sudden temperature changes, since this may cause condensation on the microphone.
- Never remove the protective grid from the microphone unless is absolutely necessary. Never touch the diaphragm. If it is very dirty, then very carefully remove the dust using a very fine camel hair brush.

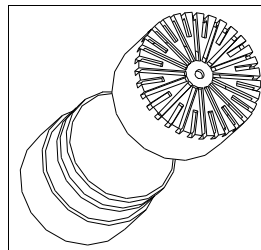

- To manipulate the device (remove the preamplifier, microphone, etc.), first it must be turned off and disconnected from the power supplies.
- Do not attempt to attach or detach the preamplifier by screwing or unscrewing the LEMO connector, as the sound level meter could be damaged.
- Remove the batteries if the SC420 is not going to be used for a long period of time.
- The SC420 sound level meter is built to work reliably for a long time. Should any anomaly occur that cannot be solved either by changing the batteries or consulting the manual, take your SC420 to an official **CESVA** dealer. Under no circumstances allow non-authorized personnel to attempt to repair the unit.
- The SC420 has an internal clock with a cell battery that lets it keep the time and programming. The average lifespan of the cell battery is 10 years. When the battery runs out, the internal calendar/clock of the SC420 returns to 00:00 hours on 01/01/2000. Enter the settings menu on the SC420 to consult the

calendar. The battery must be replaced immediately. Contact your official technical service.

- **CESVA** accepts no responsibility for unauthorised modification, alteration or repairs carried out by unauthorised personnel; any such actions will invalidate the device warranty.
- This device can only work with the accessories described in the Accessories section. Should a different accessory be used, and this leads to a fault in the device, **CESVA** accepts no responsibility for said fault, as the device is no longer covered by its warranty.

Below are the precautions and warnings to regarding the microSD memory card:

- For the *SC420* to recognise the card, it should always be inserted with the *SC420* switched off.
- Insert the card into the right slot with the label side upwards until you hear a click.
- Use cards of at least Class 4 .
- Do not touch the contact points on the microSD card.
- Do not remove the memory card while the *SC420* is switched on. Nor should you remove the card while accessing it through a PC.
- To take the card out, use only your fingers, never tools.
- For the *SC420* to function correctly, ensure any SD card is formatted before working with it for the first time.
- Erase the card memory to optimise its effectiveness. It is very important to periodically format the memory card. The card manufacturer recommends using the SD Formatter application to format the cards rather than relying on the formatting tools provided in operating systems, as these are generic and may diminish memory card performance.
- It is recommended to start measurements with the card capacity at more than 50% available.

NOTE: microSD cards of up to 4 GB have been successfully tested on the *SC420*. However, we cannot guarantee that all microSD cards will work with it.

Please bear the following advice in mind when taking measurements:

- It is advisable to check the *SC420* before and after each measurement. Use the *CB006* acoustic calibrator (see 10.1).
- When taking measurements holding the *SC420* in your hand, you must do this with your arm extended (so that it can be read) to avoid influencing the measurements (screen effect).
- To prevent interference, we recommend using the *TR050* tripod and the *CN003*, *CN010* or *CN030* microphone extension cables. Remember you can only remove the preamplifier + microphone set with the *SC420* switched off.
- The microphone's axis must point to the sound source.
- For indoor measurements it is also advisable to keep the sound level meter away from reflective surfaces: walls, objects, floors, etc.
- For acoustic measurements outside, the sound level meter microphone must be protected by the windscreen provided so that wind noise does not interfere with the measurement result. It is advisable to check the environmental conditions (temperature, humidity, atmospheric pressure).
- For long outdoor measurements, the *TK200* outdoor kit is recommended to protect the device from environmental agents (wind, rain, humidity, etc.)
- The measurement range specifications should be taken into account for the measurement of low-level sound fields. In order to measure sound levels lower than those specified by the lower limit range, the characteristics of the noise from the device itself should be taken into account.
- If anything knocks the *SC420*, this is picked up by the microphone and may alter the value of the measurement; it may also permanently damage the device.
- It is advisable to isolate the *SC420* from vibrations. Pads of foam rubber or similar materials are usually enough for this purpose.

The *SC420* can be extended using a range of modules:

- OF420: Real time spectrum analyser module in octave bands (1/1) with class 1 filters as per standard IEC 61260
- TF420: Real time spectrum analyser module in third octave bands (1/3) with class 1 filters as per standard IEC 61260
- RT420: Octave band (1/1) and third octave band (1/3) reverberation time measurement module (interrupted noise and integrated impulse method)
- DS420: Occupational noise functions evaluation module
- FF420: FFT narrow band frequency analysis module
- HI420: Analysis quality audio recording module

These optional measurement modules can be purchased at the same time as the *SC420* or later on. To incorporate them, simply contact your official **CESVA** distributor, provide them with the serial number of your sound level meter and go through the module purchase process. Within a few days, your activation programme will arrive.

23.1 Function nomenclature

The below list specifies the functions measured by the SC420 for the various measurement modes, their names and a brief definition.

23.1.1 Sound level meter mode functions

FUNCTION	DESCRIPTION
L_{XF}	Sound pressure level with X frequency weighting and fast time weighting (Fast)
L_{XFmax}	Maximum sound pressure level with X frequency weighting and fast time weighting (Fast) during measurement time
L_{XFmin}	Minimum sound pressure level with X frequency weighting and fast time weighting (Fast) during measurement time
L_{XS}	Sound pressure level with X frequency weighting and slow time weighting (Slow)
L_{XSmax}	Maximum sound pressure level with X frequency weighting and slow time weighting (Slow) during measurement time
L_{XSmin}	Minimum sound pressure level with X frequency weighting and slow time weighting (Slow) during measurement time
L_{XI}	Sound pressure level with X frequency weighting and impulse time weighting (Impulse)
L_{XImax}	Maximum sound pressure level with X frequency weighting and impulse time weighting (Impulse) during measurement time
L_{XImin}	Minimum sound pressure level with X frequency weighting and impulse time weighting (Impulse) during measurement time
	X: A, C or Z
$L_{XYmax1s}^*$	Maximum sound pressure level with X frequency weighting and time weighting Y for 1 second
$L_{XYmin1s}^*$	Minimum sound pressure level with X frequency weighting and time weighting Y for 1 second
	X: A, C or Z; Y: F, S or I

L_{Xpeak}	Peak sound pressure level of measurement time with X frequency weighting
$L_{Xpeak1s}^*$	Peak sound pressure level of 1 second with X frequency weighting X: A, C or Z
L_{nt}	Total percentiles
L_{nT}	Partial percentiles of T integration time n: 1%, 5%, 10%, 50%, 90%, 95%, 99%. Percentiles are calculated through the LAF function sampled every 125ms and with classes of 0.1 dB
L_{xt}	Equivalent continuous sound pressure level with integration time equal to the measurement time with X frequency weighting
L_{XT}	Equivalent continuous sound pressure level with T integration time with X frequency weighting
L_{XTmax}	Maximum equivalent continuous sound pressure level with T integration time with X frequency weighting
L_{XTmin}	Minimum equivalent continuous sound pressure level with T integration time with X frequency weighting
L_{X1s}^*	Equivalent continuous sound pressure level with 1 second integration time with X frequency weighting
L_{xit}	Equivalent continuous sound pressure level with impulse time weighting (Impulse) with integration time equal to the measurement time with X frequency weighting
L_{XIT}	Equivalent continuous sound pressure level with impulse time weighting (Impulse) and with T integration time with X frequency weighting
L_{XE}	Sound exposure level S.E.L. X: A, C or Z
$(L_{xit}-L_{xt})$	Dynamic subtraction of the equivalent continuous sound pressure level with time weighting 'I' and the equivalent continuous sound pressure level, corresponding to the measurement time
$(L_{ct}-L_{at})$	Dynamic subtraction of the equivalent continuous sound pressure level with frequency weighting C and the equivalent continuous sound pressure level with frequency weighting A, corresponding to the measurement time
$(L_{XIT}-L_{XT})$	Dynamic subtraction of the equivalent continuous sound pressure level with time averaging 'I' and the equivalent continuous sound pressure level, corresponding to the programmable T integration time
$(L_{CT}-L_{AT})$	Dynamic subtraction of the equivalent continuous sound pressure level with frequency weighting C and the equivalent continuous sound pressure level with frequency weighting A, corresponding to a programmable T integration time X: A, C or Z
L_{AF5t}	Taktmaximal-Mittelungspegel, corresponding to the measurement time, in compliance with standard DIN 45641
L_{AF5T}	Taktmaximal-Mittelungspegel, corresponding a programmable T integration time, in compliance with standard DIN 45641
$L_{AF5t}-L_{At}$	Dynamic subtraction of the Taktmaximal-Mittelungspegel and the equivalent continuous sound pressure level with frequency weighting A, corresponding to the measurement time

L_{AF5T-LAT}	Dynamic subtraction of the Taktmaximal-Mittelungspegel and the equivalent continuous sound pressure level with frequency weighting A, corresponding to a programmable T integration time
L_{XY125ms*}	Sound pressure level with X frequency weighting and time weighting Y every 125 milliseconds
L_{X125ms*}	Equivalent continuous sound pressure level with integration time 125 milliseconds
L_{Xpeak125ms*}	Peak sound pressure level of 125 milliseconds with X frequency weighting X: A, C or Z; Y: F, S or I
t	Measurement time
T	Programmable integration time

*: These functions are measured by the SC420 but are not displayed on screen. The results of these functions can be obtained by making a recording and then downloading it to a PC with **CESVA Lab**.

23.1.2 1/1 spectrum analyser mode functions

FUNCTION	DESCRIPTION
L_{Xt}	Equivalent continuous sound pressure level of the entire measurement with X frequency weighting
L_{XT}	Equivalent continuous sound pressure level with T integration time with X frequency weighting
L_{ft}	Equivalent continuous sound pressure level of the entire measurement of the octave band centred on frequency f
L_{fT}	Equivalent continuous sound pressure level with T integration time of the octave band centred on frequency f X: A, C or Z; f: 16, 31.5, 63, 125, 250, 500, 1000 (1k), 2000 (2k), 4000 (4k), 8000 (8k) and 16000 (16k) Hz
L_{Xpeakt}	Peak sound pressure level of measurement time with X frequency weighting
L_{XpeakT}	Peak sound pressure level of T integration time and X frequency weighting X: A, C or Z
L_{Ant}	Total global percentiles with frequency weighting A
L_{AnT}	Partial global percentiles of T integration time and frequency weighting A
L_{fnt}	Total frequency percentiles of the octave band centred on frequency f
L_{fnT}	Partial frequency percentiles of T integration time of the octave band centred on frequency f n: 1%, 5%, 10%, 50%, 90%, 95%, 99%. Percentiles are calculated through the LA125ms and Lf125ms functions with classes of 0.5 dB
L_{X125ms*}	Equivalent continuous sound pressure level with integration time 125 milliseconds with X frequency weighting

L_{f125ms}^*	Equivalent continuous sound pressure level with integration time 125 milliseconds with measurement of the octave band centred on frequency f
$L_{Xpeak125ms}^*$	Peak sound pressure level of 125 milliseconds with X frequency weighting X: A, C or Z; f: 16, 31.5, 63, 125, 250, 500, 1000 (1k), 2000 (2k), 4000 (4k), 8000 (8k) and 16000 (16k) Hz
NC	Value of the NC (Noise Criterion) curve corresponding to the measured spectrum
NC_f	Value of the NC curve that has not been exceeded in the octave band centred on frequency f
NR	Value of the NR (Noise Rating) curve corresponding to the measured spectrum
NR_f	Value on the NR curve that has not been exceeded in the octave band centred on frequency f
t	Measurement time
T	Programmable integration time

*: These functions are measured by the SC420 but are not displayed on screen. The results of these functions can be obtained by making a recording and then downloading it to a PC with **CESVA Lab**.

The global sound pressure level values with frequency weighting A, C and Z are values measured by the sound level meter and are in no case calculated by applying the discrete coefficients that define said filters to the values measured by octave band. Indeed, if they were thus calculated, appreciable differences would be observed. Frequency weighting filters are filters continuous in frequency, while the use of coefficients by bands is merely an approximation to them.

The Z filter has a zero value from 10 Hz up to 20 kHz; when measuring spectra with a high spectral content in the low frequencies (between 10 and 20 Hz), it is possible that the energetic sum of the values measured by octave bands may differ from the global value measured with frequency weighting Z.

23.1.3 1/3 Spectrum analyser mode functions

FUNCTION	DESCRIPTION
L_{Xt}	Equivalent continuous sound pressure level of the entire measurement with X frequency weighting
L_{XT}	Equivalent continuous sound pressure level with T integration time with X frequency weighting
L_{AIt}	Equivalent continuous sound pressure level with impulse time weighting (Impulse) of the entire measurement with frequency weighting A
L_{AIT}	Equivalent continuous sound pressure level with impulse time weighting (Impulse) and with T integration time and with frequency weighting A
L_{AYmaxt}	Maximum sound pressure level with frequency weighting A and time weighting Y during measurement time
L_{AYmaxT}	Maximum sound pressure level with frequency weighting A and time weighting Y during T integration time
L_{ft}	Equivalent continuous sound pressure level of the entire measurement of the third octave band centred on frequency f

L_{fT}	Equivalent continuous sound pressure level with T integration time of the third octave band centred on frequency f X: A, C or Z; Y: F, S or I; f: 10, 12.5, 16, 20, 25, 31.5, 40, 50, 63, 80, 100, 125, 160, 200, 250, 315, 400, 500, 630, 800, 1000 (1k), 1250 (1.25k), 1600 (1.6k), 2000 (2k), 2500 (2.5k), 3150 (3.15k), 4000 (4k), 5000 (5k), 6300 (6.3k), 8000 (8k), 10000 (10k), 12500 (12.5k), 16000 (16k) and 20000 (20k) Hz
L_{Ant}	Total global percentiles with frequency weighting A
L_{AnT}	Partial global percentiles of T integration time and frequency weighting A n: 1%, 5%, 10%, 50%, 90%, 95%, 99%. Percentiles are calculated through the LA125ms and Lf125ms functions with classes of 0.5 dB
$(L_{AIt}-L_{At})$	Dynamic subtraction of the equivalent continuous sound pressure level with time weighting 'I' and the equivalent continuous sound pressure level, corresponding to measurement time t (with frequency weighting A)
$(L_{AFmaxT}-L_{At})$	Dynamic subtraction of the maximum equivalent continuous sound pressure level with time weighting 'F' and the equivalent continuous sound pressure level, corresponding to measurement time t (with frequency weighting A)
$(L_{AlmaxT}-L_{AFmaxT})$	Dynamic subtraction of the maximum equivalent continuous sound pressure level with time weighting 'I' and the maximum equivalent continuous sound pressure level with frequency weighting 'F', corresponding to measurement time t (with frequency weighting A)
$(L_{AlmaxT}-L_{ASmaxT})$	Dynamic subtraction of the maximum equivalent continuous sound pressure level with time weighting 'I' and the maximum equivalent continuous sound pressure level with frequency weighting 'S', corresponding to measurement time t (with frequency weighting A)
$(L_{Ct}-L_{At})$	Dynamic subtraction of the equivalent continuous sound pressure level with frequency weighting C and the equivalent continuous sound pressure level with frequency weighting A, corresponding to the measurement time t
$(L_{AIT}-L_{AT})$	Dynamic subtraction of the equivalent continuous sound pressure level with time weighting 'I' and the equivalent continuous sound pressure level corresponding to T integration time (with frequency weighting A)
$(L_{AFmaxT}-L_{AT})$	Dynamic subtraction of the maximum sound pressure level with time weighting 'F' and the equivalent continuous sound pressure level, corresponding to T integration time (with frequency weighting A)
$(L_{AlmaxT}-L_{AFmaxT})$	Dynamic subtraction of the maximum sound pressure level with time weighting 'I' and the maximum sound pressure level with frequency weighting 'F', corresponding to an T integration time (with frequency weighting A)
$(L_{AlmaxT}-L_{ASmaxT})$	Dynamic subtraction of the maximum sound pressure level with time weighting 'I' and the maximum sound pressure level with frequency weighting 'S', corresponding to an T integration time (with frequency weighting A)
$(L_{CT}-L_{AT})$	Dynamic subtraction of the equivalent continuous sound pressure level with frequency weighting C and the equivalent continuous sound pressure level with frequency weighting A, corresponding to T integration time
L_{X125ms}^*	Equivalent continuous sound pressure level with integration time 125 milliseconds with X frequency weighting
$L_{AI125ms}^*$	Equivalent continuous sound pressure level with impulse time weighting (Impulse), integration time 125 milliseconds and frequency weighting A

$L_{AYmax125ms}^*$	Maximum sound pressure level with frequency weighting A and time weighting Y during integration time 125 milliseconds
L_{f125ms}^*	Equivalent continuous sound pressure level with integration time 125 milliseconds of the third octave band centred on frequency f X: A, C or Z; Y: F, S or I; f: 10, 12.5, 16, 20, 25, 31.5, 40, 50, 63, 80, 100, 125, 160, 200, 250, 315, 400, 500, 630, 800, 1000 (1k), 1250 (1.25k), 1600 (1.6k), 2000 (2k), 2500 (2.5k), 3150 (3.15k), 4000 (4k), 5000 (5k), 6300 (6.3k), 8000 (8k), 10000 (10k), 12500 (12.5k), 16000 (16k) and 20000 (20k) Hz
t, T	Measurement time and programmable integration time

*: These functions are measured by the SC420 but are not displayed on screen. The results of these functions can be obtained by making a recording and then downloading it to a PC with **CESVA Lab**.

The global sound pressure level values with frequency weighting A, C and Z are values measured by the sound level meter and are in no case calculated by applying the discrete coefficients that define said filters to the values measured by octave band. Indeed, if they were thus calculated, appreciable differences would be observed. Frequency weighting filters are filters continuous in frequency, while the use of coefficients by bands is merely an approximation to them.

The Z filter has a zero value from 10 Hz up to 20 kHz; when measuring spectra with a high spectral content in the low frequencies (between 10 and 20 Hz), it is possible that the energetic sum of the values measured by octave bands may differ from the global value measured with frequency weighting Z.

23.1.4 Octave (1/1) and third octave (1/3) band reverberation time mode functions

FUNCTION	DESCRIPTION
L_{Nf}	Sound pressure level of the background noise measurement of the octave (or third octave) band centred on frequency f
Δ_f	Increase in sound pressure level of the octave (or third octave) band centred on frequency f
T_{20f}	Reverberation time T_{20} of the octave (or third octave) band centred on frequency f
T_{30f}	Reverberation time T_{30} of the octave (or third octave) band centred on frequency f
ξ_{T20f}	Non-linearity parameter for T_{20} of the octave (or third octave) band centred on frequency f
ξ_{T30f}	Non-linearity parameter for T_{30} of the octave (or third octave) band centred on frequency f
Cf	Curvature parameter of the octave (or third octave) band centred on frequency f
B^*T_{20f}	Product B^*T_{20} of the octave (or third octave) band centred on frequency f
B^*T_{30f}	Product B^*T_{30} of the octave (or third octave) band centred on frequency f

f: 16, 31.5, 63, 125, 250, 500, 1000 (1k), 2000 (2k), 4000 (4k), 8000 (8k) and 16000 (16k) Hz for octave bands and 10, 12.5, 16, 20, 25, 31.5, 40, 50, 63, 80, 100, 125, 160, 200, 250, 315, 400, 500, 630, 800, 1000 (1k), 1250 (1.25k), 1600 (1.6k), 2000 (2k), 2500 (2.5k), 3150 (3.15k), 4000 (4k), 5000 (5k), 6300 (6.3k), 8000 (8k), 10000 (10k), 12500 (12.5k), 16000 (16k) and 20000 (20k) Hz for third octave bands

23.1.5 Occupational noise mode functions

FUNCTION	DESCRIPTION
L_{At}	Equivalent continuous sound pressure level of the entire measurement with frequency weighting A
L_{Ct}	Equivalent continuous sound pressure level of the entire measurement with frequency weighting C
L_{AT}	Equivalent continuous sound pressure level with T integration time with frequency weighting A
L_{CT}	Equivalent continuous sound pressure level with T integration time with frequency weighting C
L_{ft}	Equivalent continuous sound pressure level of the entire measurement of the octave band centred on frequency f
L_{fT}	Equivalent continuous sound pressure level with T integration time of the octave band centred on frequency f f: 63, 125, 250, 500, 1000 (1k), 2000 (2k), 4000 (4k) and 8000 (8k) Hz
L_{Cpeakt}	Peak sound pressure level of measurement time with frequency weighting C
L_{CpeakT}	Peak sound pressure level of T integration time with frequency weighting C
$L_{EX,8h}$	Daily noise exposure level normalised to 8 hours, with frequency weighting A
$L_{EX,8hp}$	Daily noise exposure level normalised to 8 hours projected at time t_p , with frequency weighting A
E	Measurement time noise exposure
E_p	Noise exposure projected at time t_p
DOSE	Measurement time dose
DOSE _p	Dose projected at time t_p
t	Measurement time
T	Programmable integration time
t_p	Programmable time of projection

23.1.6 FFT analyser mode functions

FUNCTION	DESCRIPTION
L_{Xft}	Continuous sound pressure level equivalent with X frequency weighting of the entire measurement of the line centred on frequency f X: A or Z; f: 10000 lines of constant bandwidth between 0 and 20000 Hz. 2Hz/line
t	Measurement time

23.2 Function description

This section briefly describes the functions measured by the SC420 for the various measurement modes.

23.2.1 Sound pressure level with Fast and Slow time weightings

LF (Fast)

RMS value with 125 ms fast exponential averaging, in decibels.

LS (Slow)

RMS value with 1 s slow exponential averaging, in decibels.

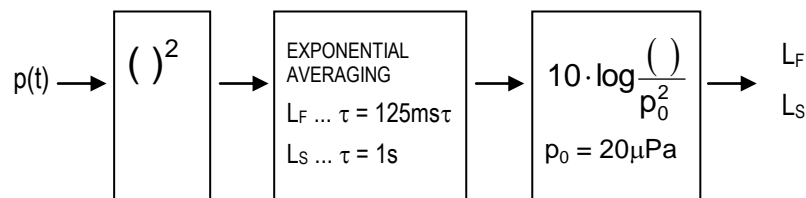

$p(t)$: instantaneous sound pressure

To obtain a stable reading, sound level meters feature two kinds of responses, known as fast and slow. The fast response has an exponential averaging circuit time constant of $\tau = 125 \text{ ms}$ and the slow response has one of $\tau = 1 \text{ s}$.

The "fast" response is indicated in the measurement of noise levels that fluctuate relatively little. Meanwhile, the "slow" response is recommended for noises of greater variation.

$$L_{S,F} = 20 \cdot \log \left(\frac{\left(\frac{1}{\tau} \int_{-\infty}^{\tau} p^2(\zeta) \cdot e^{-(t-\zeta)/\tau} d\zeta \right)^{1/2}}{p_0} \right)$$

$p(t)$: instantaneous sound pressure

p_0 : reference sound pressure (20 μPa)

23.2.2 Sound pressure level with Impulse time weighting

LI (Impulse)

Maximum short-term RMS value with exponential averaging of 35 ms, in decibels.

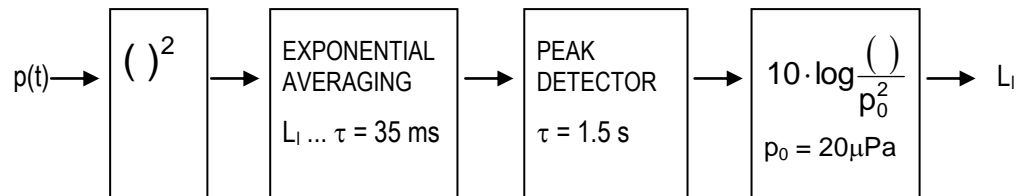

$p(t)$: instantaneous sound pressure

The Impulse feature is designed to detect impulse noise, like shots or blows. The impulse function has a very fast exponential averaging circuit time constant of $\tau = 35\text{ms}$ and a peak detector that retains the measured value for long enough to be viewed.

23.2.3 Peak sound pressure level

L_{peak} (Peak)

The highest absolute instantaneous sound pressure value from the beginning of the measurement, in decibels.

23.2.4 Equivalent continuous sound pressure level

L_T and L_t

The linear averaged of the square of the instantaneous sound-pressure from the very start, t_1 , until the end, t_2 . The duration of the averaged is therefore $T = t_2 - t_1$

$$L_T = 10 \cdot \log \left(\frac{1}{T} \int_{t_1}^{t_2} \frac{p^2(t)}{p_0^2} dt \right)$$

$p(t)$: instantaneous sound pressure

p_0 : reference sound pressure (20 μPa)

T : duration of the averaged

The equivalent sound pressure level is the pressure level that, kept constant throughout the entire measurement interval, has the same sound energy as the sound event measured.

The equivalent continuous sound pressure level function is ideal for measuring variable sound events such as road traffic or sound events that due to their long

duration cover a wide range of sound pressure levels, such as environmental measurements.

Percentile levels are the perfect complement to the equivalent continuous sound pressure level function.

The *SC420* measures the equivalent continuous sound pressure level L_t and L_T .

The equivalent level L_t is the equivalent level of the interval measured, that is, for each instant it gives us the value of the equivalent level from the beginning of the measurement to that instant. When measurement has been completed, the L_t value corresponds to the equivalent level of the entire measurement from beginning to end.

The equivalent level L_T is the equivalent level corresponding to T integration time (a programmable parameter). Every time T interval is presented. That is, every T interval, the *SC420* shows the equivalent level of the last T interval.

23.2.5 Taktmaximal-Mittelungspegel

$L_{AF5t}(t)$ (Taktmaximal pegel)

The maximum value of the Fast level $L_F(t)$ measured for a time interval of 5 seconds, with frequency weighting A.

L_{AF5t} and L_{AF5T} (Taktmaximal-Mittelungspegel)

L_{AF5t}

The equivalent continuous sound pressure level of the measured values of $L_{AF5t}(t)$, corresponding to the measurement time.

L_{AF5T}

The equivalent continuous sound pressure level of the measured values of $L_{AF5t}(t)$, corresponding to T integration time (programmable parameter).

23.2.6 Sound exposure level (SEL)

L_E (SEL Sound Exposure Level)

Sound exposure level. This is the sound level that, kept constant for 1 second, presents energy equivalent to the energy accumulated throughout the entire measurement, in decibels.

$$L_E = 10 \cdot \log \left(\frac{1}{T_0} \int_0^t \frac{p^2(t)}{p_0^2} dt \right)$$

$p(t)$: instantaneous sound pressure

p_0 : reference sound pressure (20 μ Pa)

t : duration of the measurement

T_0 : 1 second

Its relation with the equivalent continuous sound pressure level is as follows:

$$L_t = L_E - 10 \cdot \log\left(\frac{t}{T_0}\right)$$

23.2.7 Percentile levels

L_{99} , L_{95} , L_{90} , L_{50} , L_{10} , L_5 and L_1

The levels that have been exceeded during 99%, 95%, 90%, 50%, 10%, 5% and 1% of the measurement time, in decibels.

In Sound Level Meter mode, they are calculated with classes of 0.1 dB using the function L_{AF} . In the 1/1 and 1/3 spectrum analyser modes, they are calculated with classes of 0.5 dB from the L_{AT} function.

23.2.8 Decay curve

Decay curve

Decay of the sound pressure level according to time at a point in the room after the source is stopped. This decay can be measured after the real cut of a continuous sound source in the room being studied.

23.2.9 Impulse response

Impulse response

Time history of the sound pressure observed at a point in the room as a result of the emission of a Dirac impulse at another point in the room.

23.2.10 Integrated impulse response method

Integrated impulse response method

Method for obtaining decay curves through the inverse integration of the impulse response time to the square according to the Schroeder method.

23.2.11 Reverberation Time

T_{30}

The time, in seconds, that is required for the sound pressure level to decrease by 60 dB, calculated on a line from a lineal regression by least squares approximation of a decay curve measured from a level 5 dB below the initial level, to a level 35 dB lower than that initial level.

T_{20}

The time, in seconds, that is required for the sound pressure level to decrease by 60 dB, calculated on a line from a lineal regression by least squares

approximation of a decay curve measured from a level 5 dB below the initial level, to a level 25 dB lower than that initial level.

The reverberation time of a room is one of the most important parameters to evaluate its acoustics properties. Its measurement has important applications in the field of noise control in rooms, concert halls and lecture rooms. The reverberation time measurement is essential for calculation of acoustic insulation in buildings and of building elements, and for the measurement of the absorption coefficient in a reverberation room.

The reverberation time parameter is defined in the International Standards ISO 3382-1 and ISO 3382-2.

23.2.12 Quality parameters (ξ , C and B·T values)

ξ

The non-linearity parameter is entered per thousand with regard to perfect linearity:

$$\xi = 1000(1-r^2)$$

r: Correlation coefficient

C

The curvature parameter is based on the two evaluation ranges of 20 dB and 30 dB and is entered as the percentage deviance with regard to a perfectly straight line:

$$C = 100 \cdot \left(\frac{T_{30}}{T_{20}} - 1 \right)$$

B·T

This product is used to make a traditional prospective analysis that appraises the reliability of the results obtained by a filter and a detector. Therefore, the lower limits to obtain reliable results must be:

$$B \cdot T > 16$$

B: is the bandwidth of the filter, in Hertz

T: is the reverberation time measured, in seconds

23.2.13 Equivalent daily noise exposure level

$L_{EX,8h}$

Daily noise exposure level normalised to 8 hours, with frequency weighting A.

$$L_{EX,8h} = L_{At} + 10 \log \left(\frac{t}{T_0} \right)$$

L_{At} : Equivalent continuous sound pressure level with frequency weighting A corresponding to the measurement time

t : Measurement time

T_0 : Normalisation time 8 hours

23.2.14 Sound exposure

E

Integral of the square of the instantaneous sound pressure over a specified measurement time, expressed in $\text{Pa}^2 \cdot \text{h}$

$$E = \int_0^t p_A^2(t) \cdot dt$$

$p_A(t)$: Instantaneous sound pressure with frequency weighting A

23.2.15 Dose

DOSE

Relationship between the energy corresponding to the measurement period and the maximum energy permitted in relation to the criterion level L_C over 8 hours, expressed as a percentage (%).

$$\text{DOSE} = 10^{\frac{(L_{EX,8h} - L_C)}{10}}$$

$L_{EX,8h}$: Equivalent daily noise exposure level (dBA).

L_C : Criterion level (dBA).



Maracaibo, 6 • 08030 BARCELONA, SPAIN

Tel. (+34) 934 335 240 • FAX (+34) 933 479 310

info@cesva.com • www.cesva.com

CESVA
instruments, s.l.u. reserves the right to amend the characteristics and accessories in this manual without prior notice.